

3171341COM 2 Door Vanity Closet Unit

systembuild[®]
EVOLUTION

Date of Purchase ___ / ___ / ___
Lot Number:

B343171341COM0

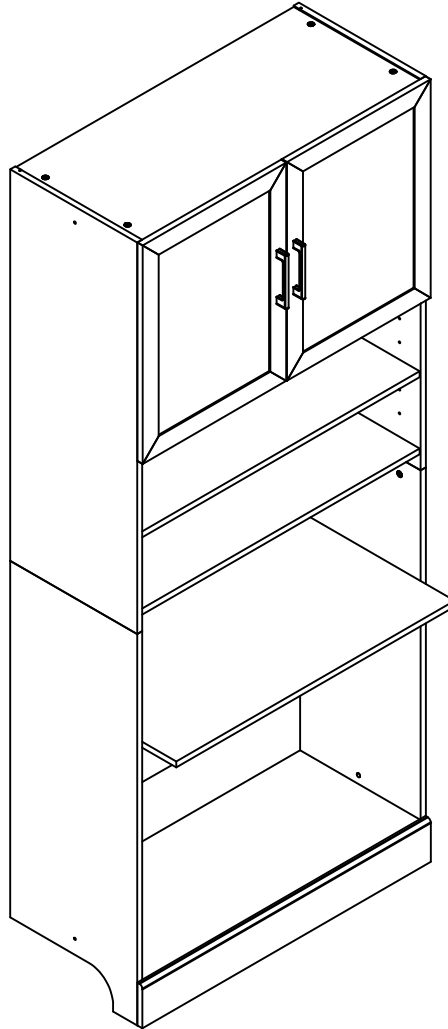

THIS INSTRUCTION BOOKLET CONTAINS **IMPORTANT** SAFETY INFORMATION. PLEASE READ AND KEEP FOR FUTURE REFERENCE.

Do Not Return This Product!

Contact our customer service team for help first.

Call: 1-800-489-3351 (toll free)

Monday-Friday 9am - 5pm CST

Visit: www.systembuild.com



WARNING

- Unit can tip over causing severe injury or death.
- Anchor unit to stud in wall (if instructed to).
- Do Not allow children to climb on unit.
- Put heavy items on lower shelves or drawers.



Easy Tough
Assembly Difficulty Meter

For the latest information on SystemBuild products
follow us at Ameriwood Home



Contact Us!

Do NOT return this product!

Contact our friendly customer service team first for help.

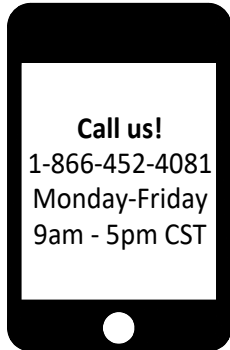

Visit systembuild.com to view the limited warranty valid in the U.S. and Canada.

Assembly Tips



Helpful Hints

PEOPLE NEEDED FOR ASSEMBLY: 1-2
ESTIMATED ASSEMBLY TIME: 1 HOUR

- Open your item in the area you plan to keep it to avoid excessive heavy lifting.
- Identify, sort and count the parts before attempting assembly.
- Compression dowels are lightly tapped in with a hammer.
- Slides are labeled with a **R** (right) and **L** (left) for proper placement.
- Make sure to always face the point on the top of the Cam Lock towards the outer edge.
- Use all the nails provided for the back panel and spread them out equally.
- Back panel must be used to make sure your unit is sturdy.
- Do NOT use harsh chemicals or abrasive cleaners on this item.
- Never push, pull, or drag your furniture.

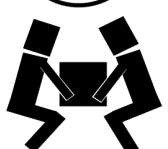

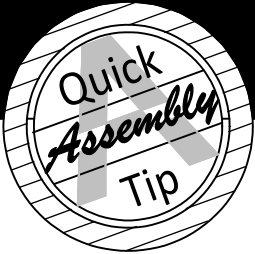

Before You Start

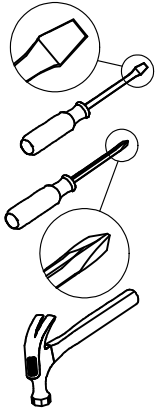

- ✓ Read through each step carefully and follow the proper order
- ✓ Separate and count all your parts and hardware
- ✓ Give yourself enough room for the assembly process
- ✓ Have the following tools: Flat Head Screwdriver, #2 Phillips Head Screwdriver and Hammer
- ✓ Caution: If using a power drill or power screwdriver for screwing, please be aware to slow down and stop when screw is tight. Failure to do so may result in stripping the screw.

Cam Lock Fastening System

This Cam Lock Fastening System will be used throughout the assembly process.

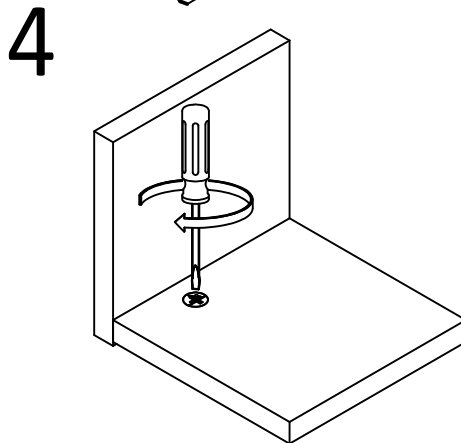
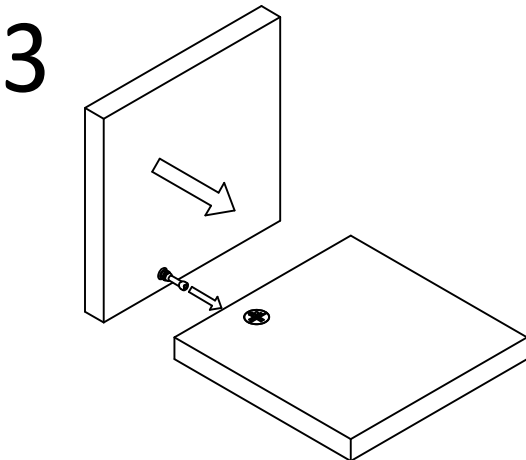
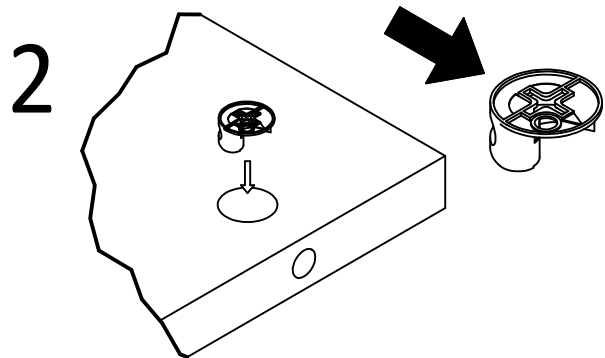
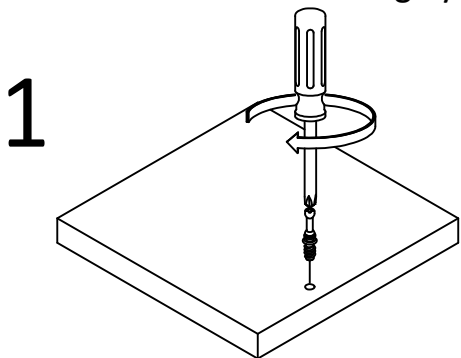

Please Note:

You may need to lightly tap the wood dowels into the holes during your assembly process.

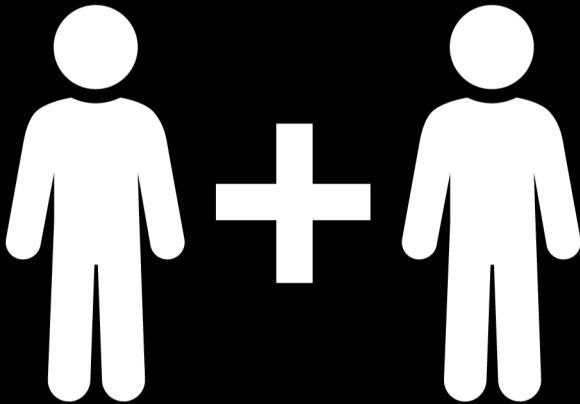
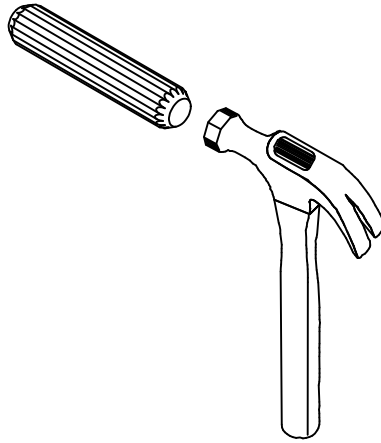

2 PEOPLE NEEDED FOR ASSEMBLY

**2 PERSONAS NECESITADAS
PARA LA ASAMBLEA**

**2 PERSONNES NÉCESSAIRES
POUR L'ASSEMBLAGE**

CAUTION: Failure to use 2 people for assembly could result in unit damage or personal injury.

PRECAUCIÓN: Si no se utilizan 2 personas para el ensamblaje, se pueden producir daños en la unidad o lesiones personales.

ATTENTION: Échec d'utiliser 2 personnes pour l'assemblage peut causer du dommage au meuble ou causer des blessures.

Board Identification

Not actual size

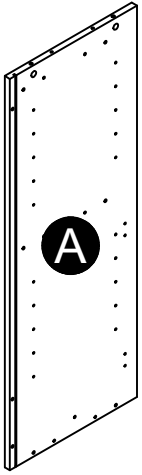

Left
Upper Panel
33171341010

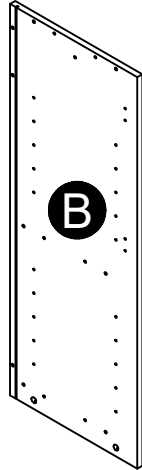

Right
Upper Panel
33171341020

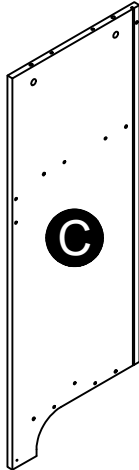

Left
Lower Panel
33171341030

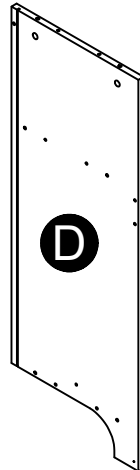

Right
Lower Panel
33171341040

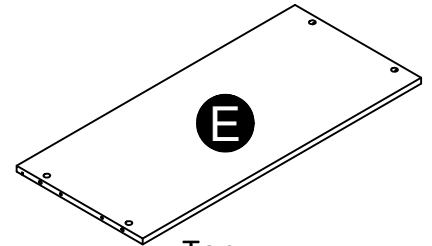

Top
33171341050

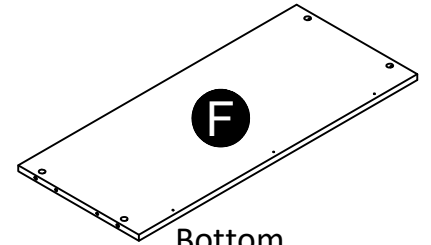

Bottom
33171341060

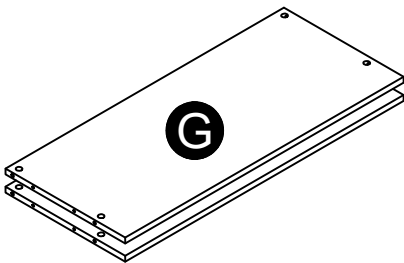

Shelf (x2)
33171341070

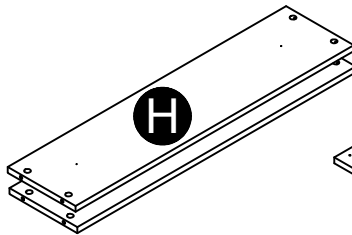

Support (x2)
33171000080

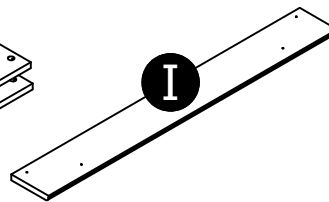

Kick
33171341090

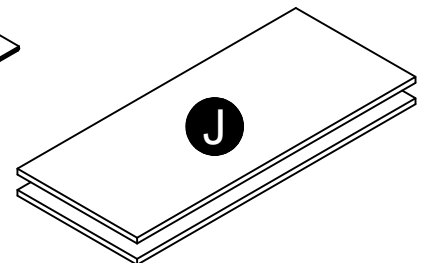

Adjustable Shelf (x2)
33171341100

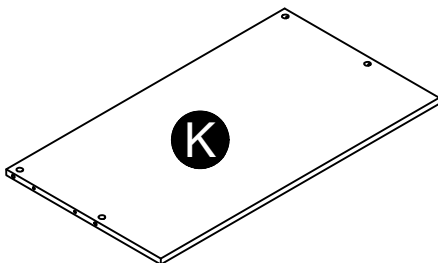

Vanity Top
33171341110

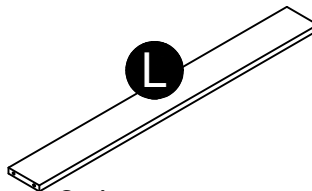

Stringer
33171341120

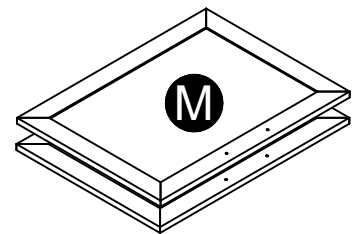

Door (x2)
33171341130

Board Identification

Not actual size

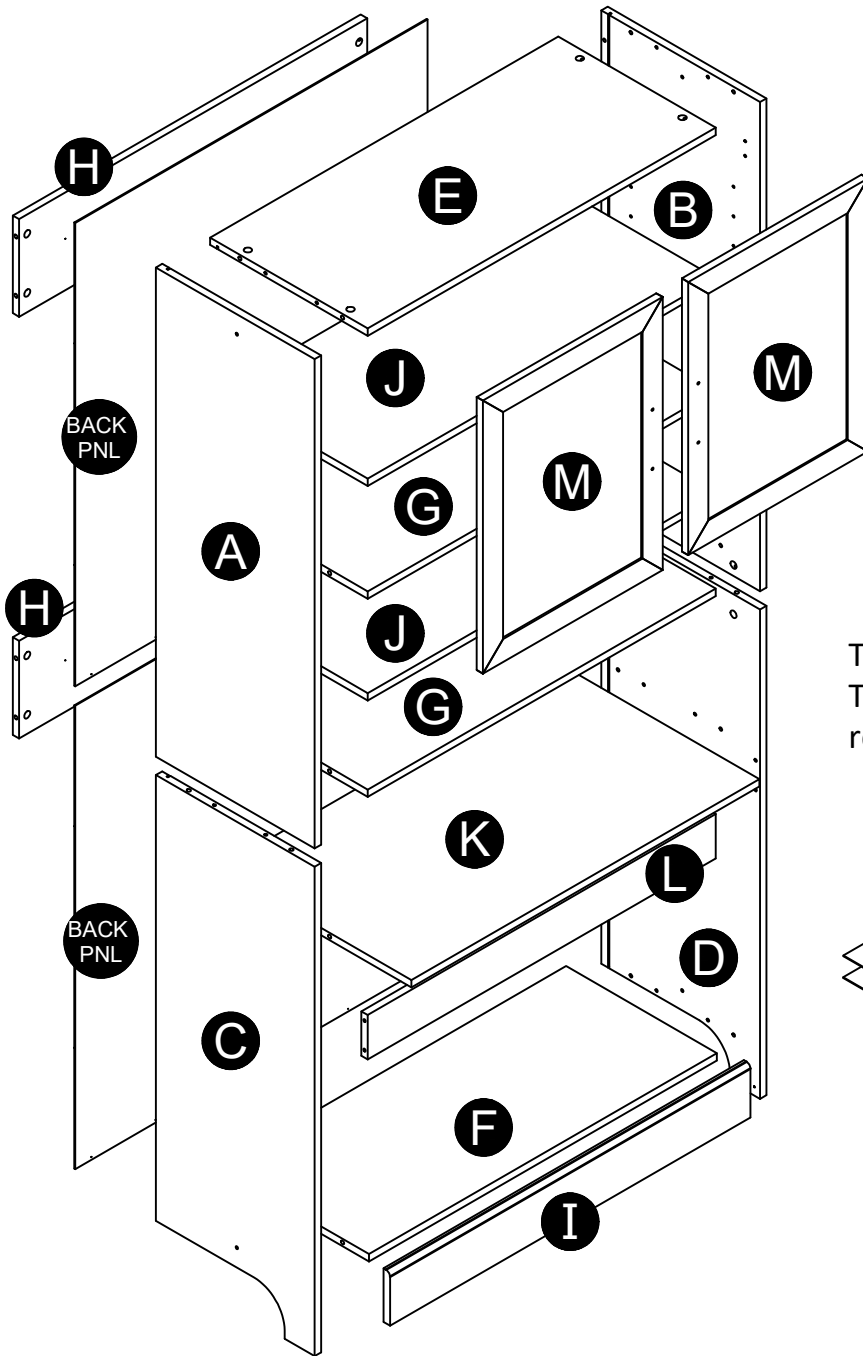

These pieces are paperboard construction. They are not made from wood, but are required for the assembly of your unit.

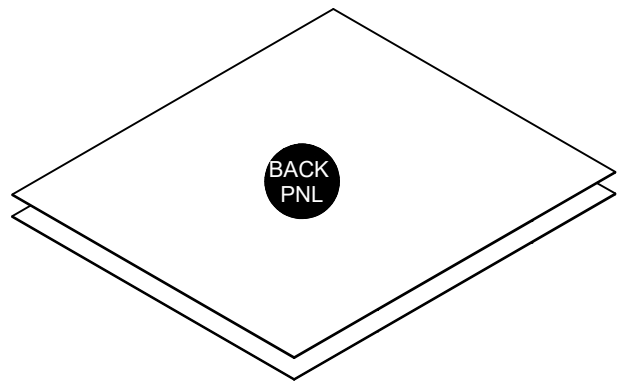

Back Panel (x2)
K317134100

Part List

Actual Size

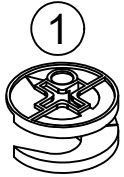

(x36)
#A22620
cam lock

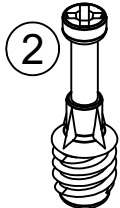

(x28)
#A22610
cam bolt

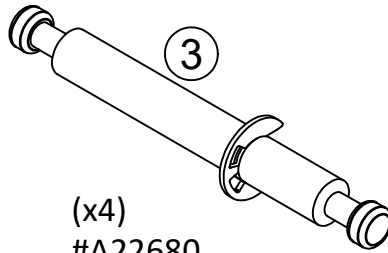

(x4)
#A22680
double cam bolt



(x10)
#A12120
7/16" pan head

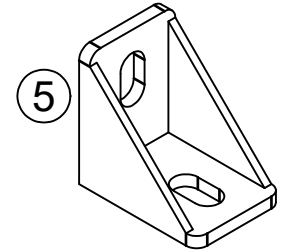

(x5)
#A53510
angle bracket

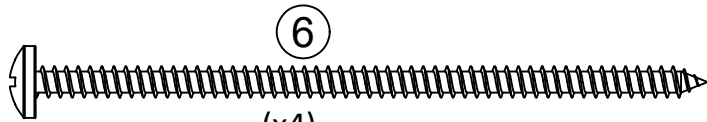

(x4)
#A13950
3-1/2" screw

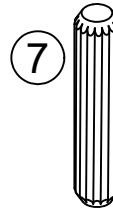

(x28)
#A21670
wood dowel



(x2)
#A17200
1/2" bolt

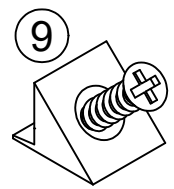

(x8)
#A54710
wedge



(x4)
#A17400
7/8" bolt

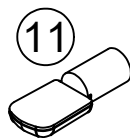

(x8)
#A80250
shelf support

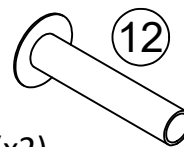

(x2)
#A22940
chicago fastener



(x6)
#A21110
nail

Part List

Not Actual Size

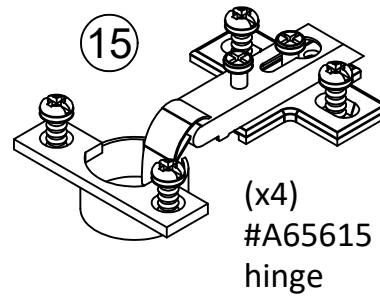
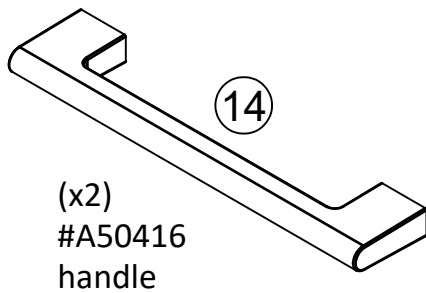

STEP 1

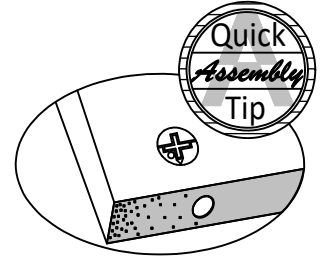
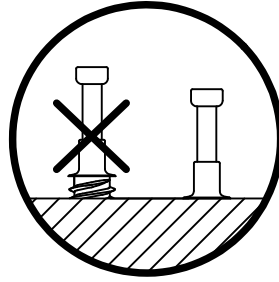
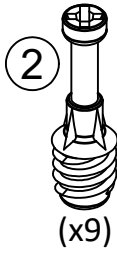
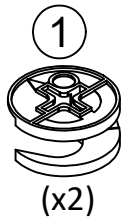
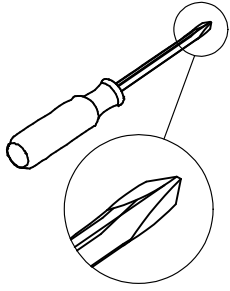

Proper orientation of CAM LOCK

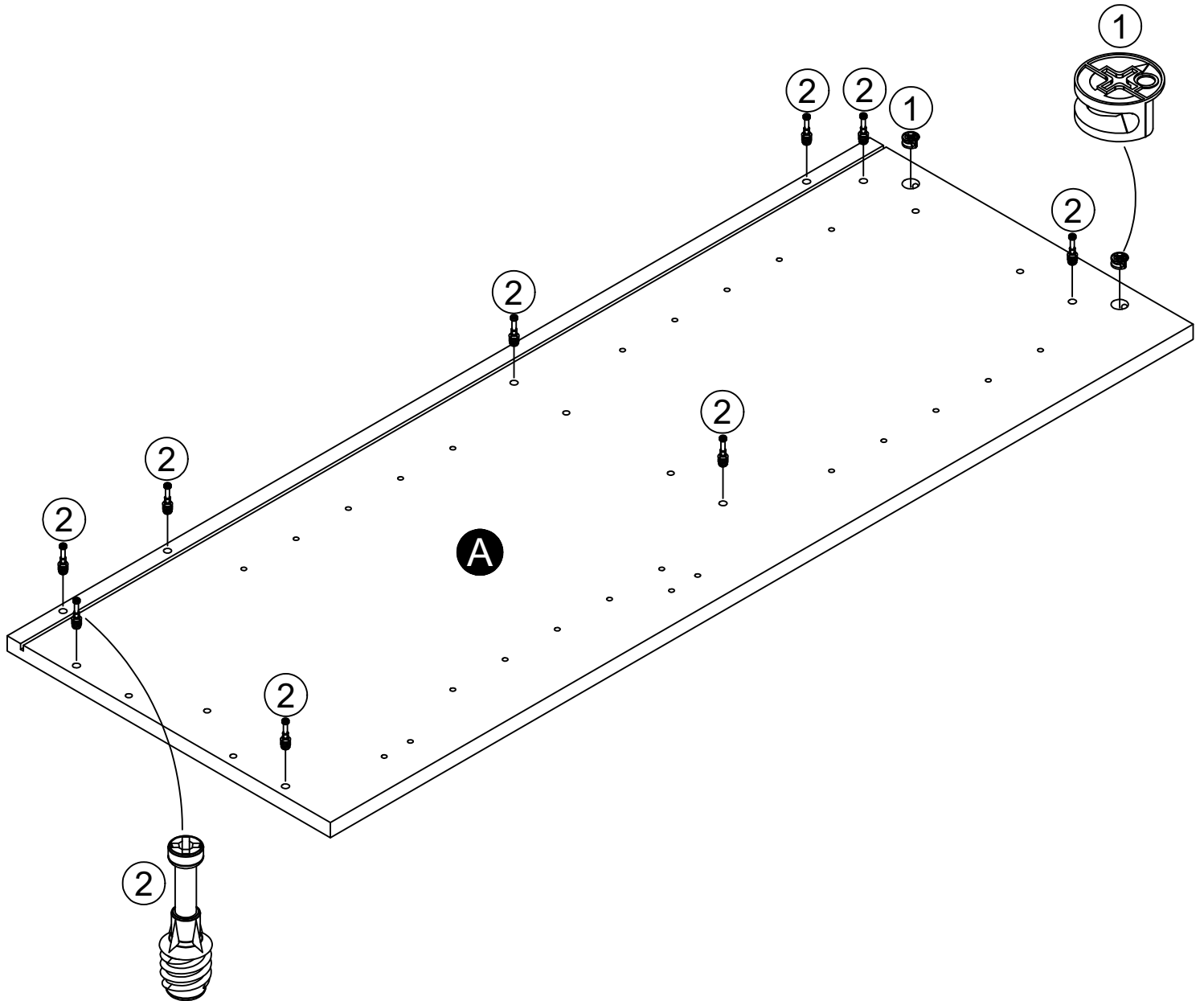

STEP 2

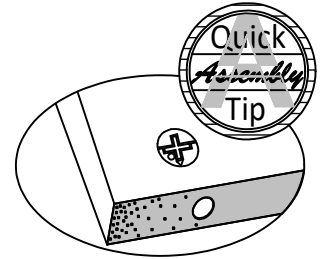
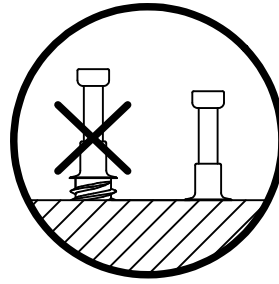
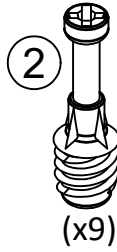
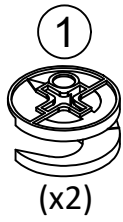
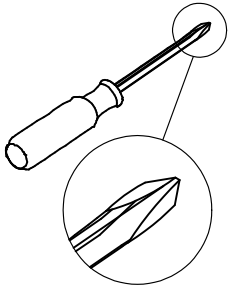

Proper orientation of CAM LOCK

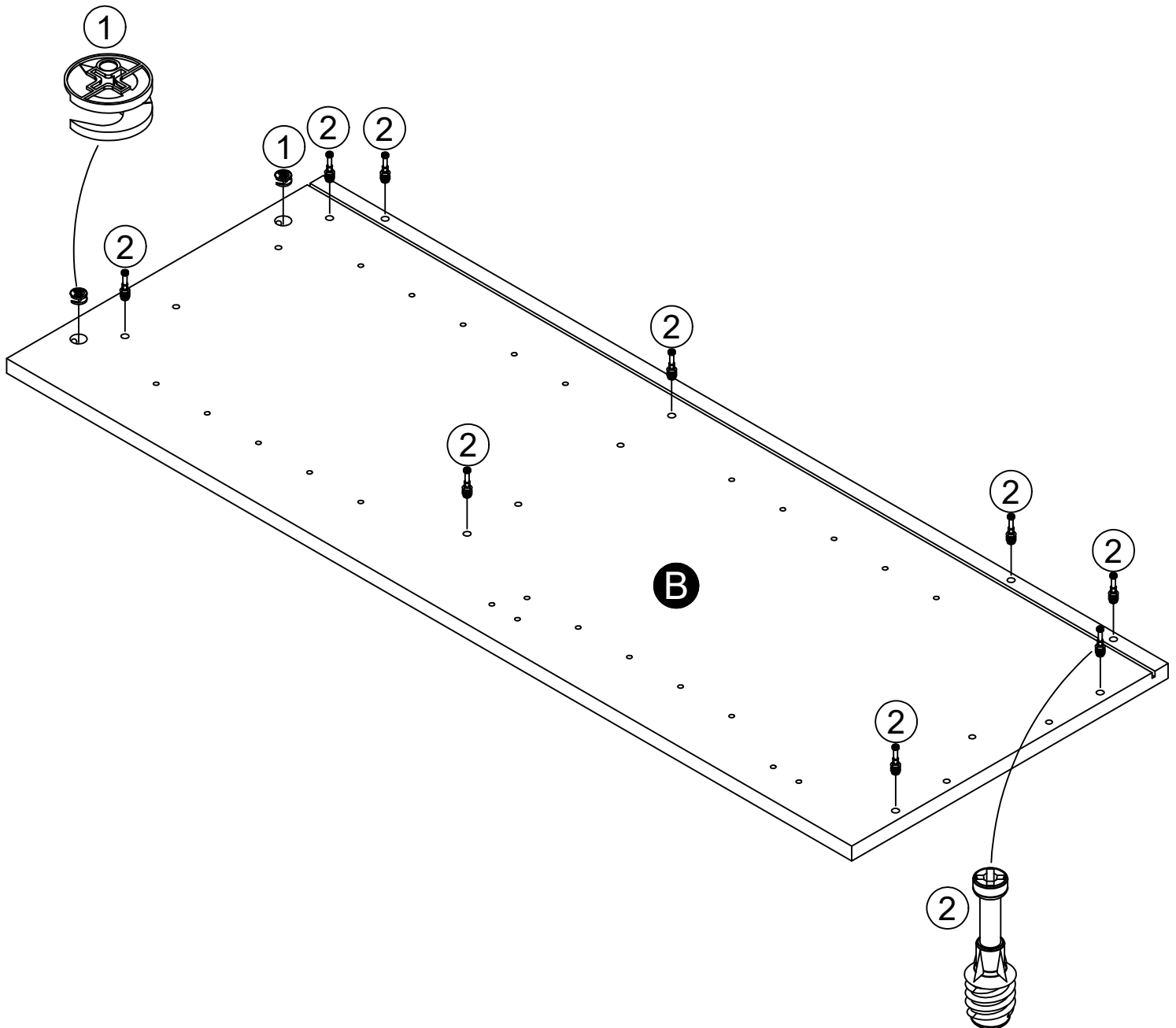

STEP 3

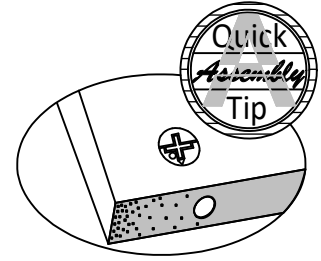
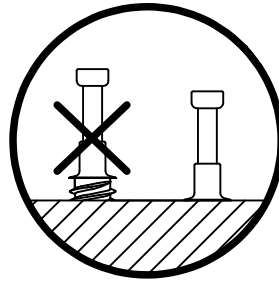
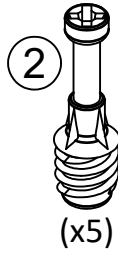
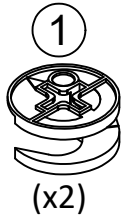
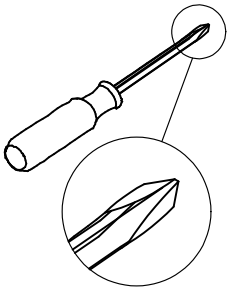

Proper orientation of CAM LOCK

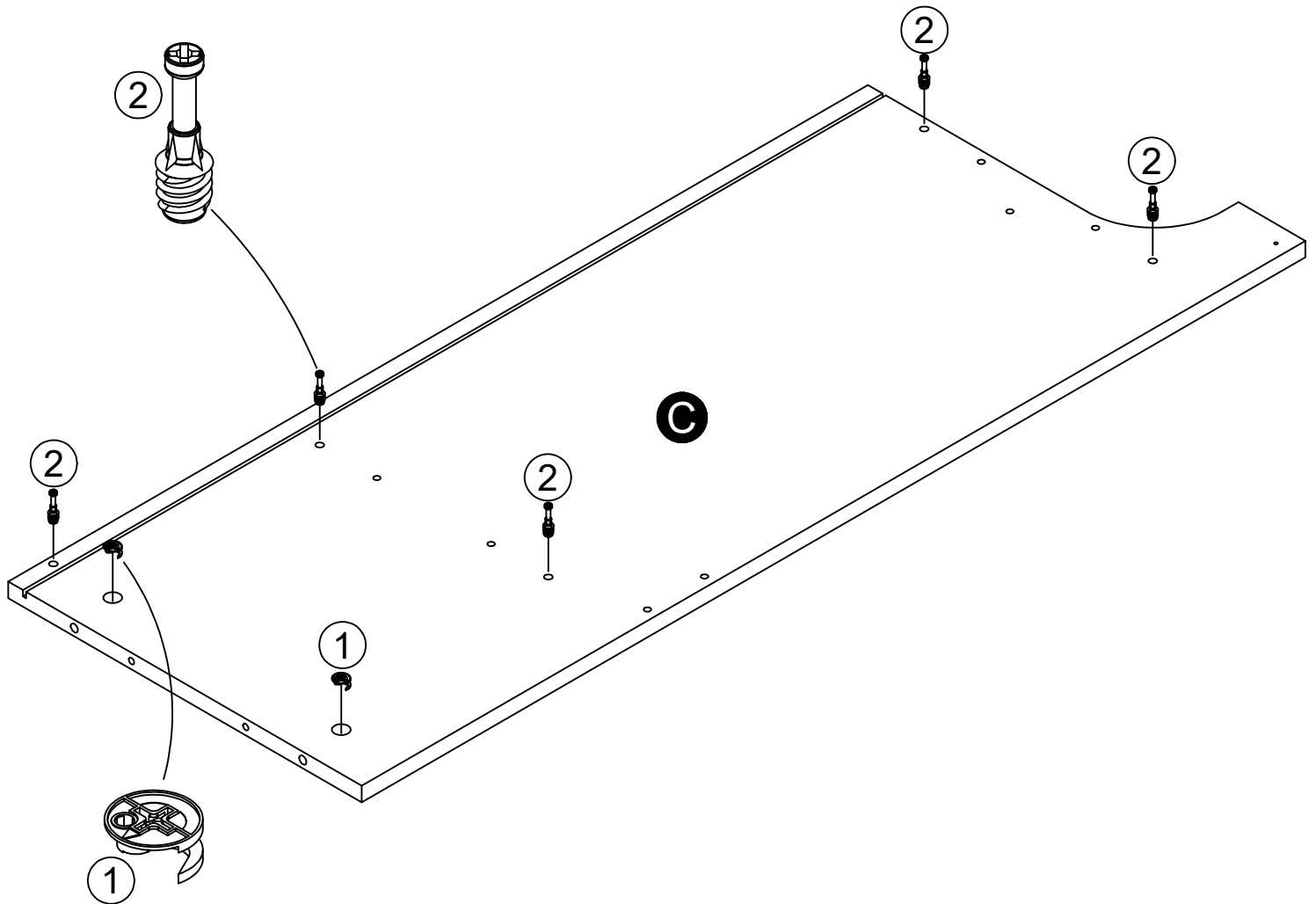

STEP 4

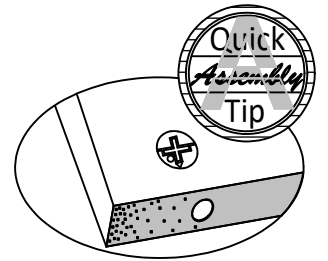
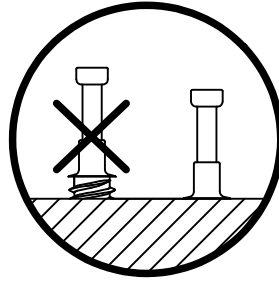
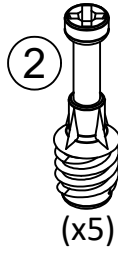
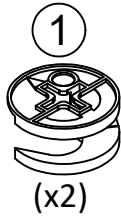
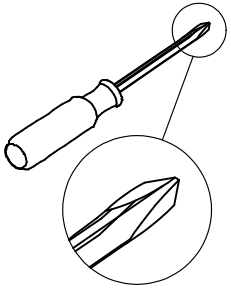

Proper orientation of CAM LOCK

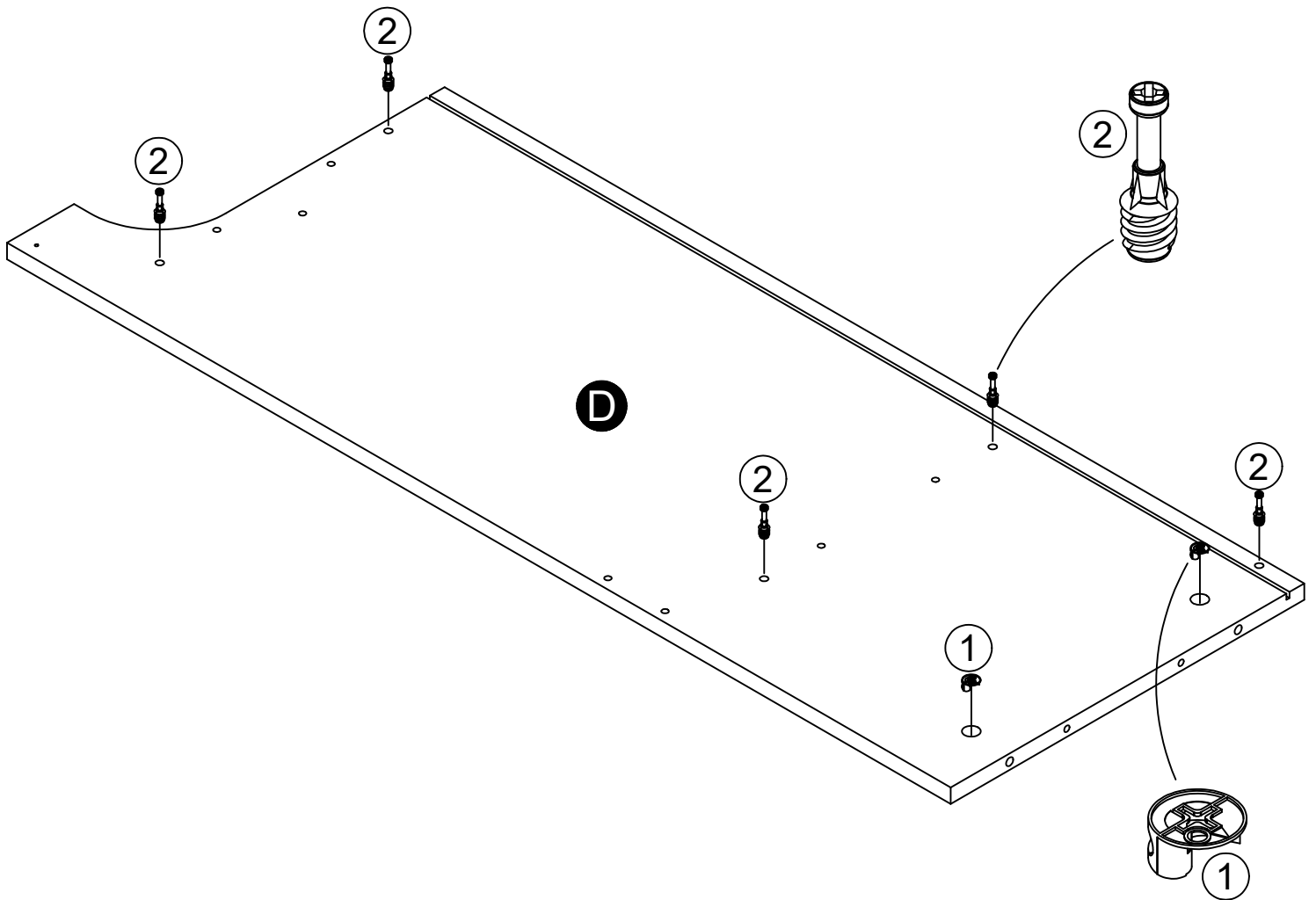

STEP 5

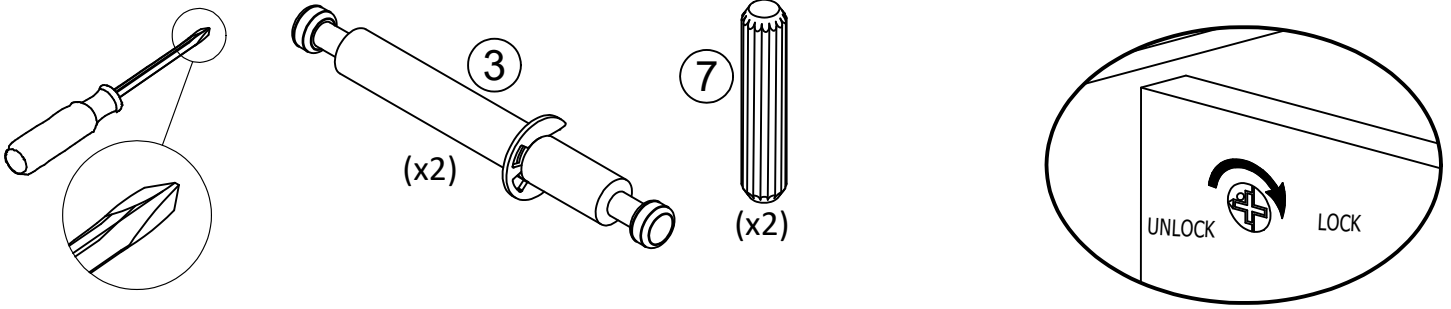

Insert two Double Cam Bolts (3) and two Wood Dowels (7). Press the two panels together and tighten the four Cam Locks (1).

Note:
Insert the short end into part A.

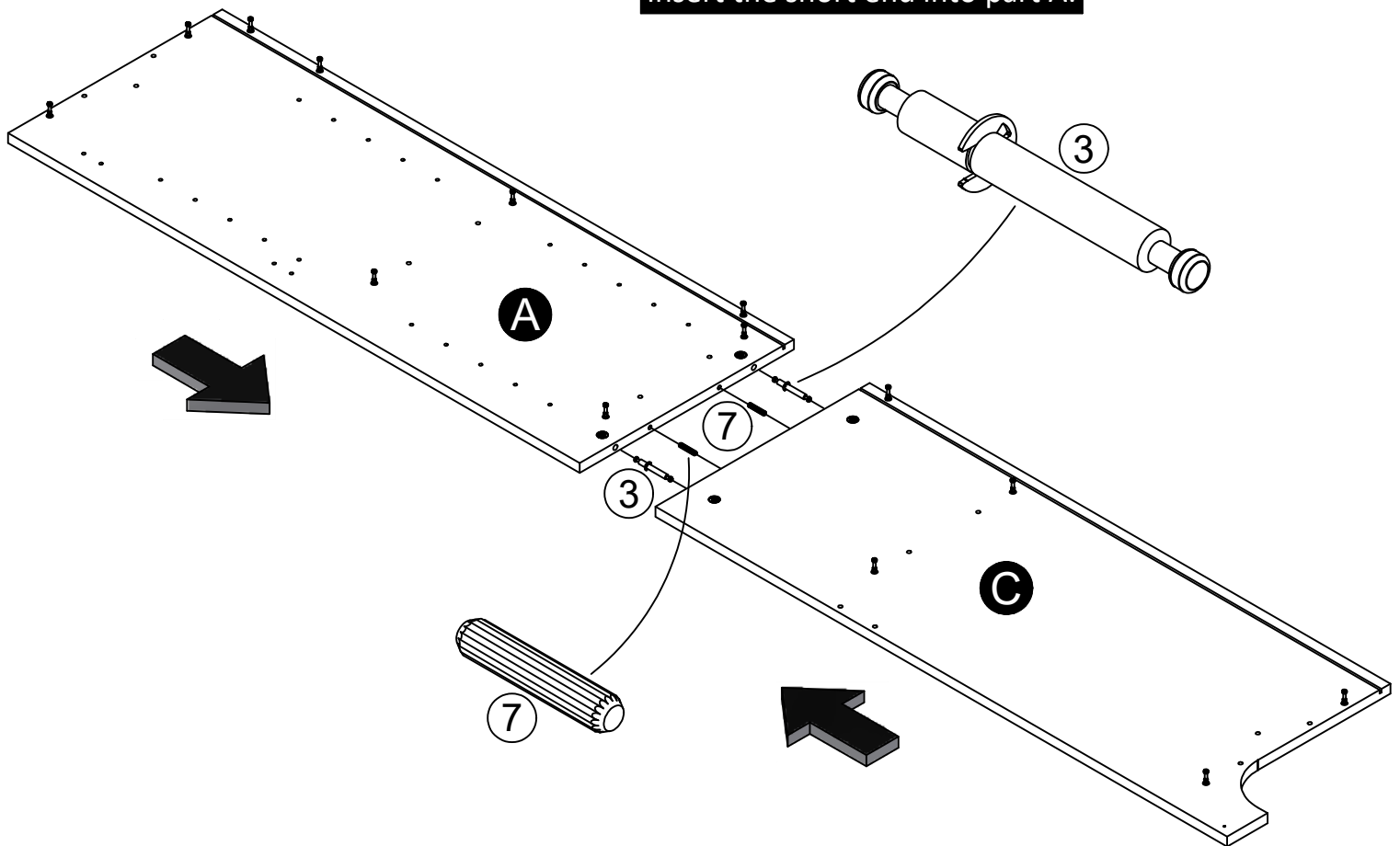

STEP 6

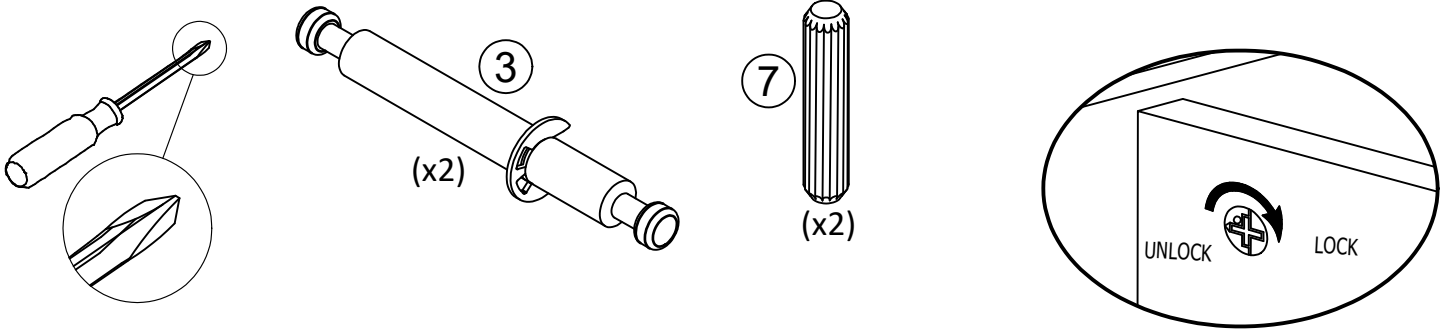

Insert two Double Cam Bolts (3) and two Wood Dowels (7). Press the two panels together and tighten the four Cam Locks (1).

Note:
Insert the short end into part B.

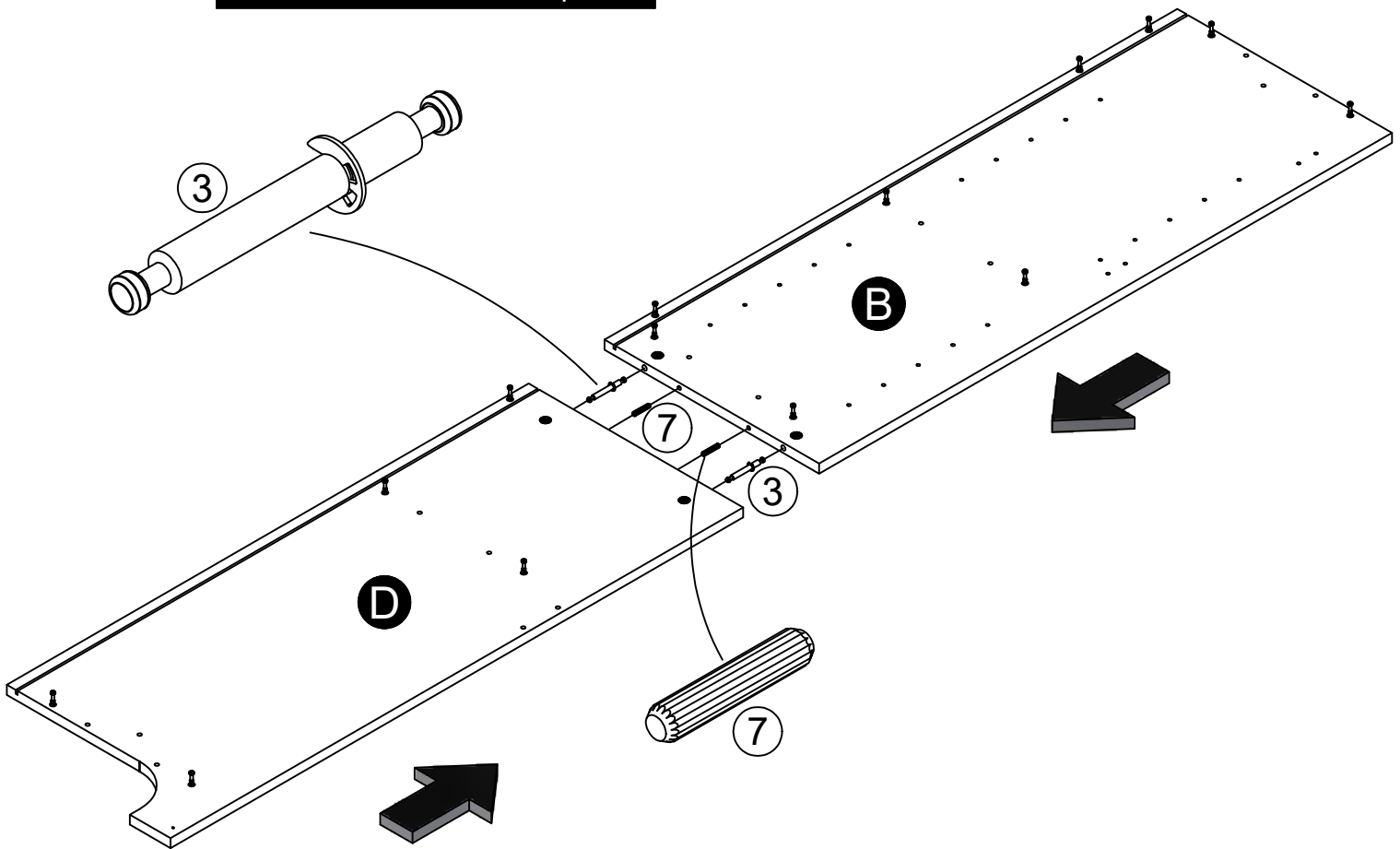

STEP 7

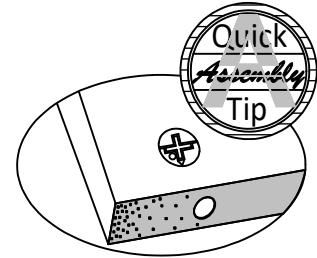
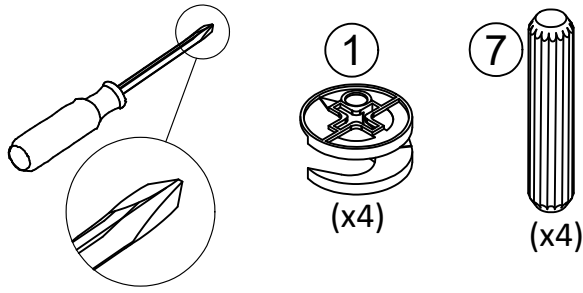

Proper orientation of CAM LOCK

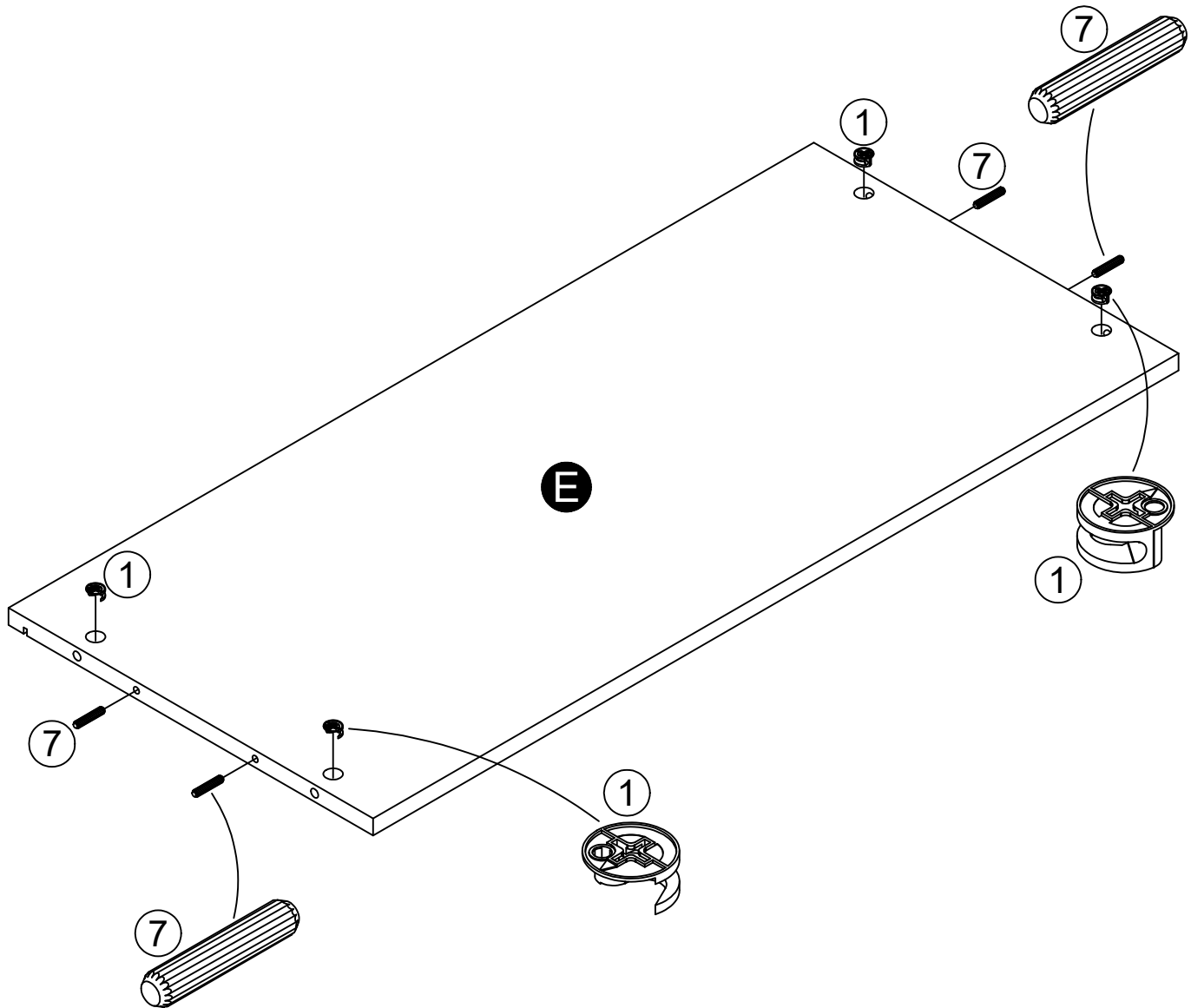

STEP 8

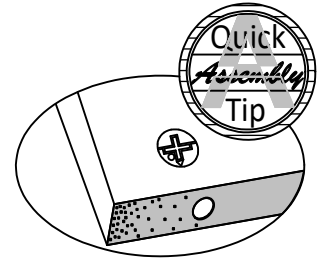
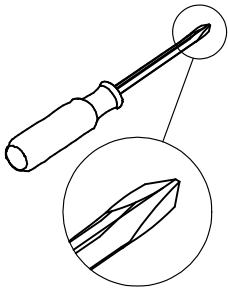

Proper orientation of CAM LOCK

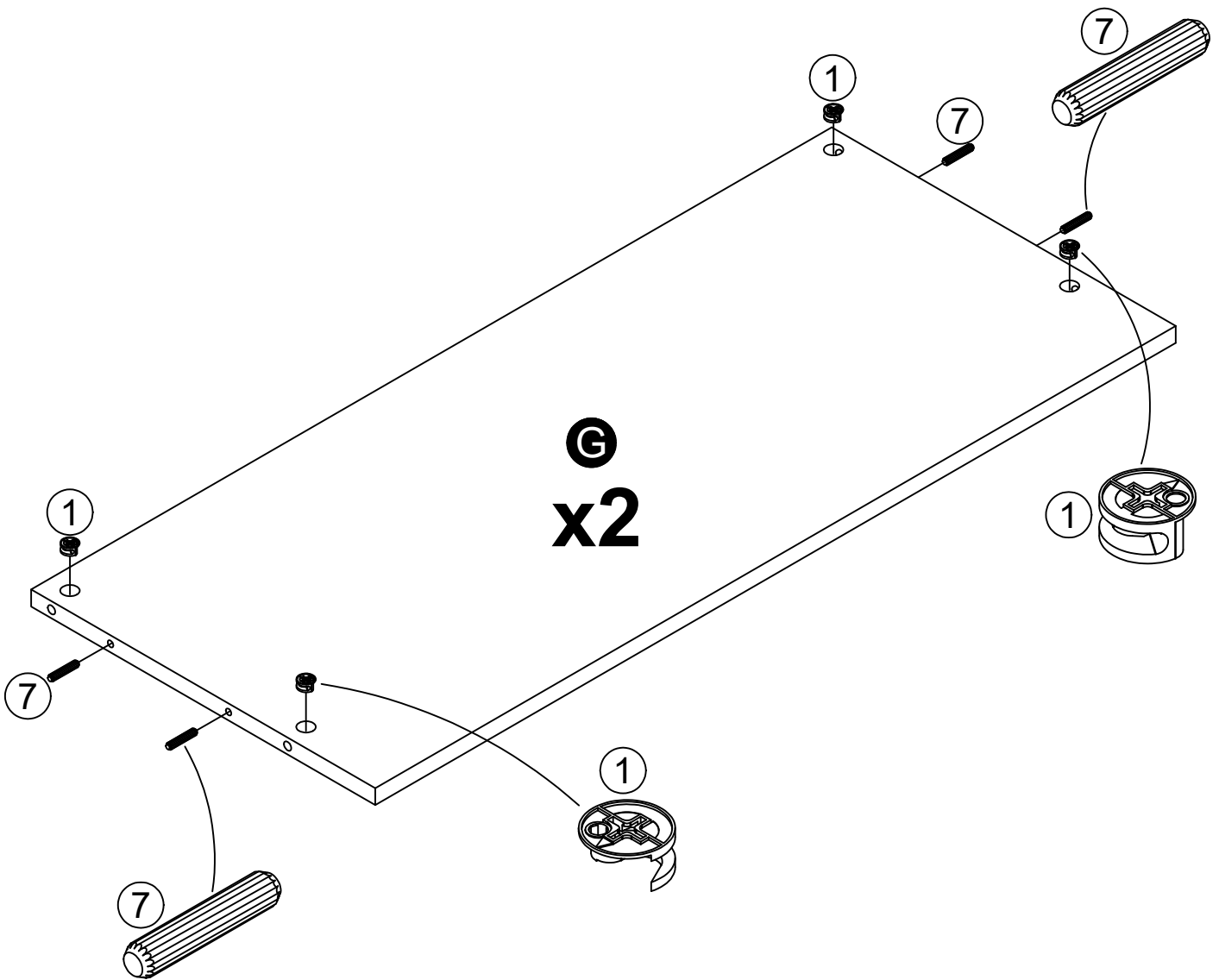

STEP 9

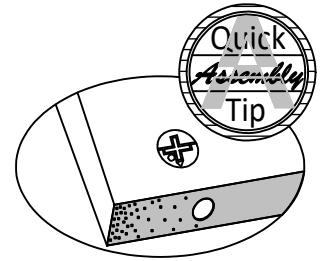
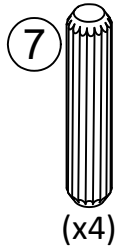
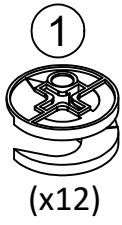

Proper orientation of CAM LOCK

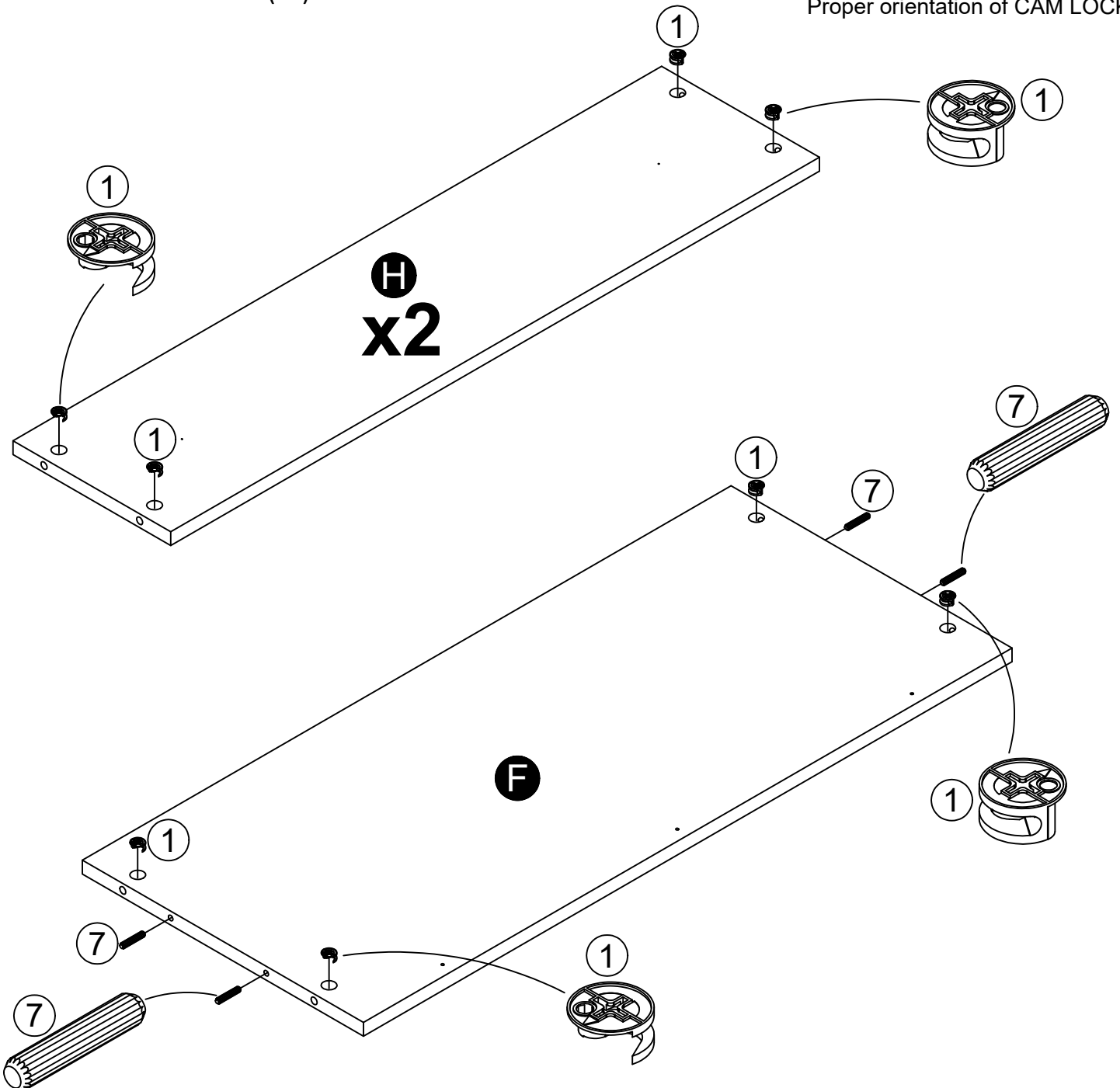

STEP 10

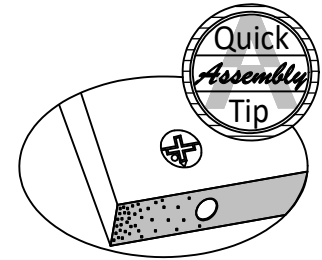
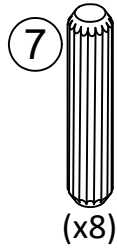
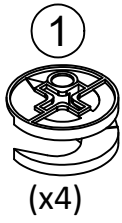

Proper orientation of CAM LOCK

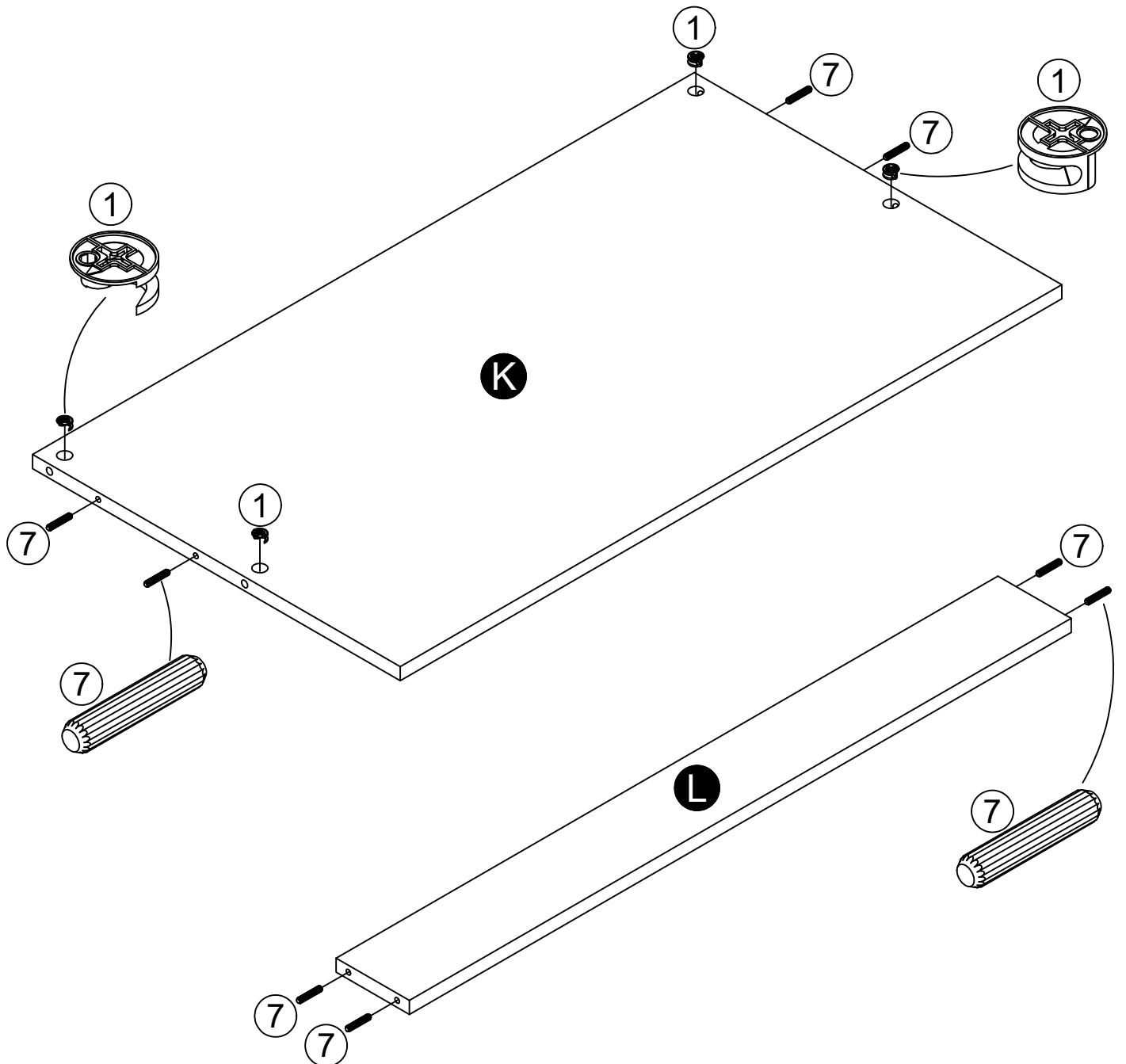

STEP 11

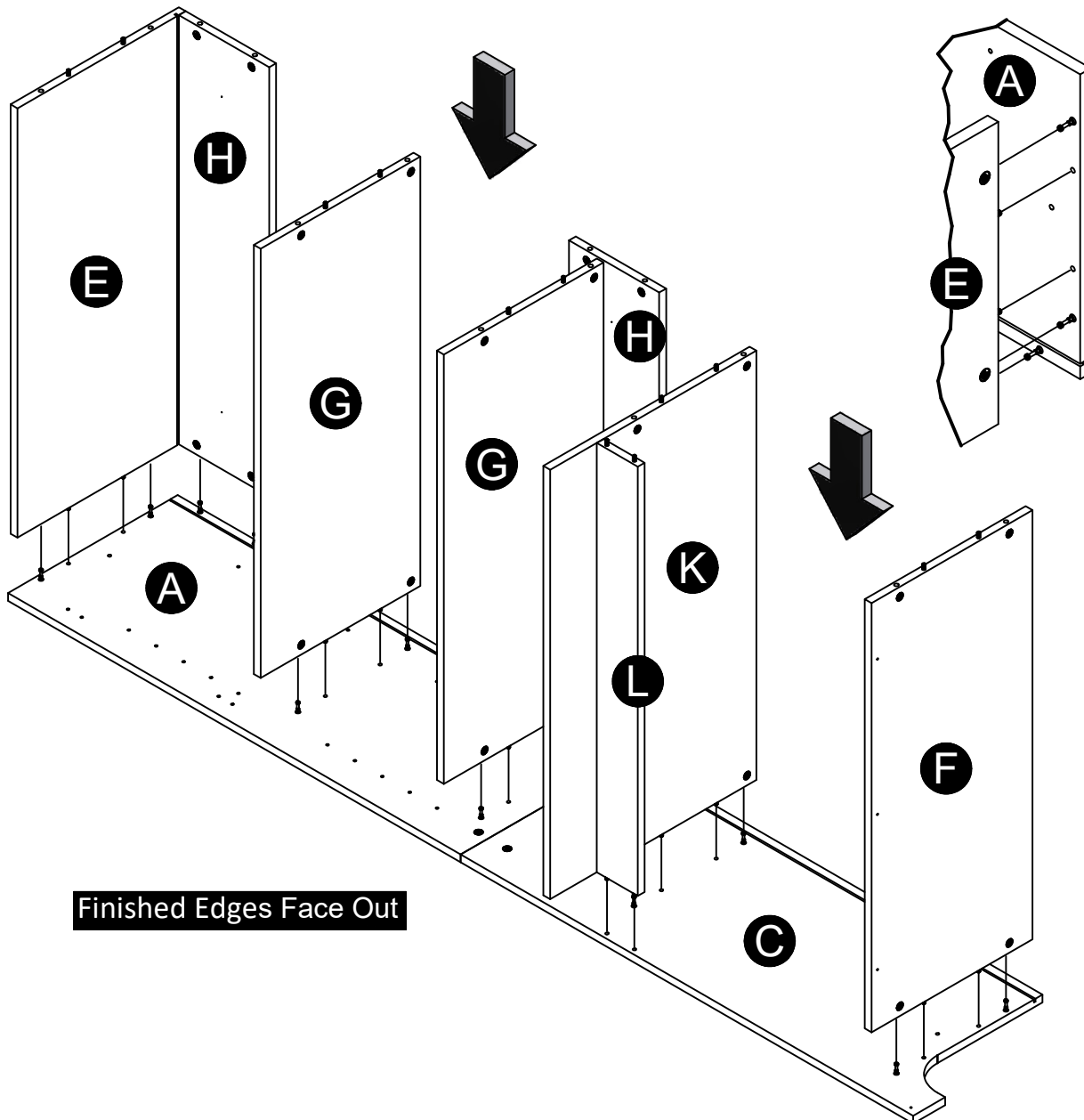
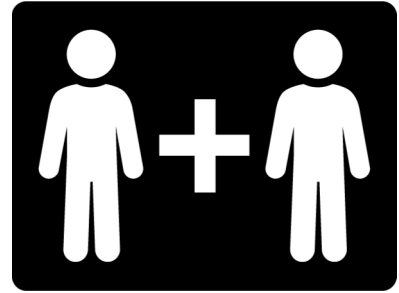
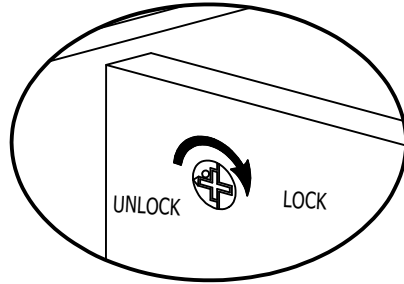
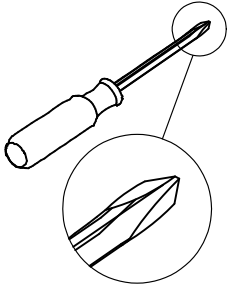

Finished Edges Face Out

STEP 12

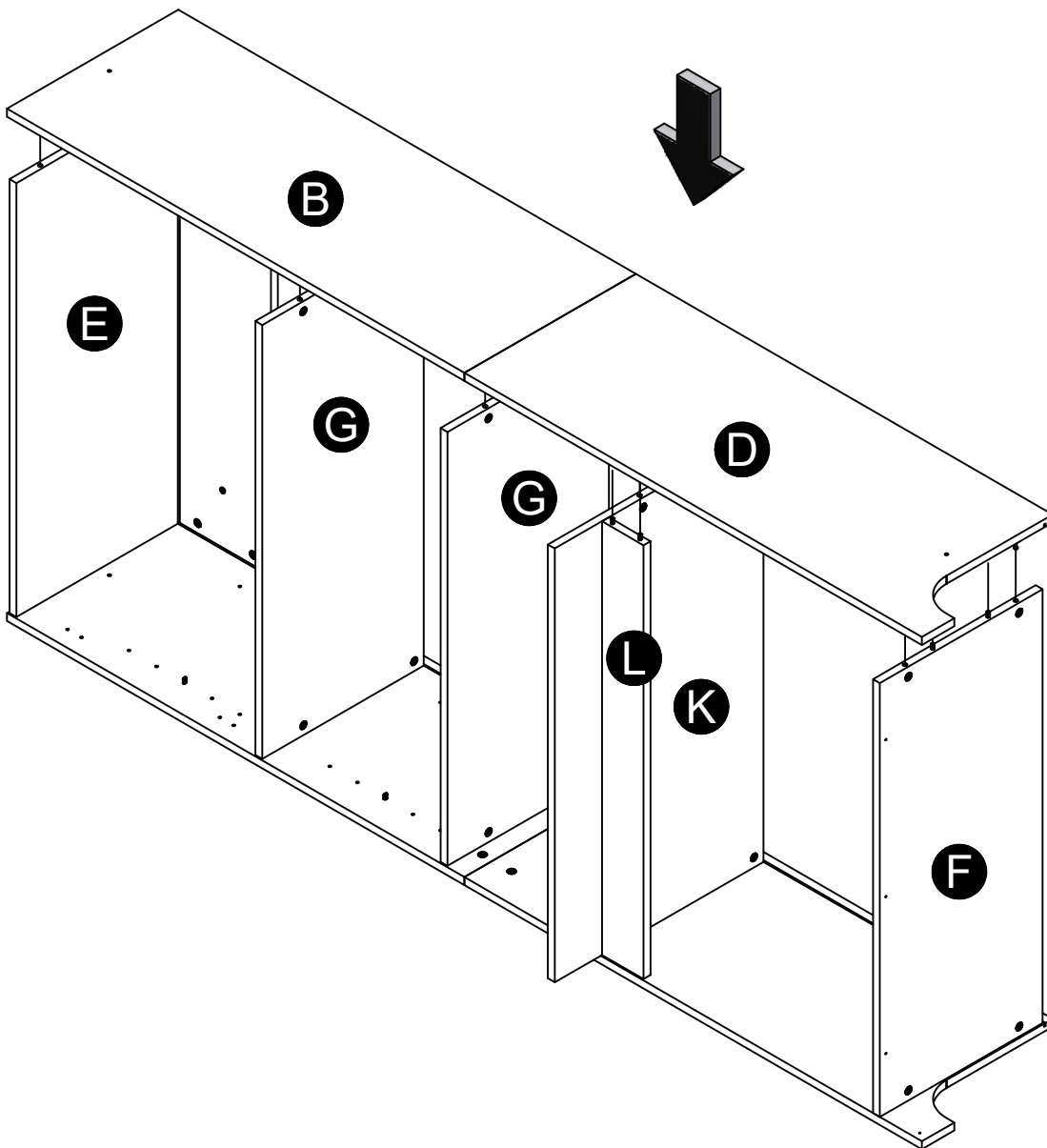
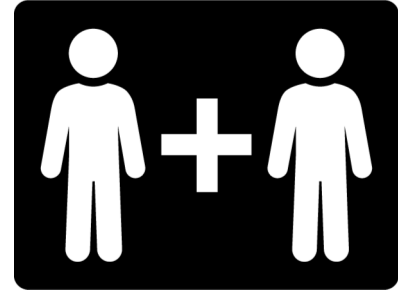
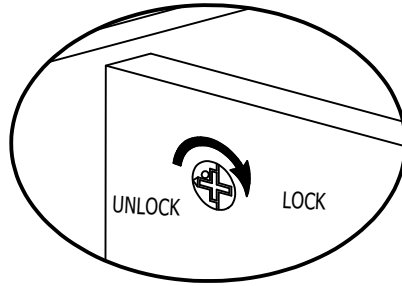
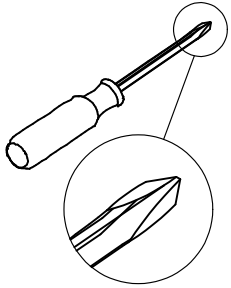

STEP 13

IMPORTANT! THE BACK PANEL IS A STRUCTURAL PART OF THIS UNIT AND MUST BE INSTALLED PROPERLY.

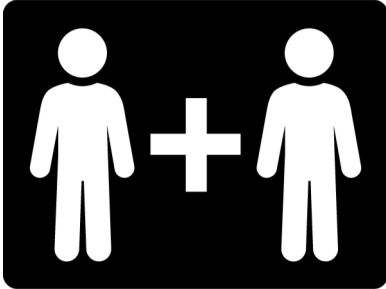

Insert one of the Back Panels into the grooves and slide all the way until it insert into the groove of the Top (E).

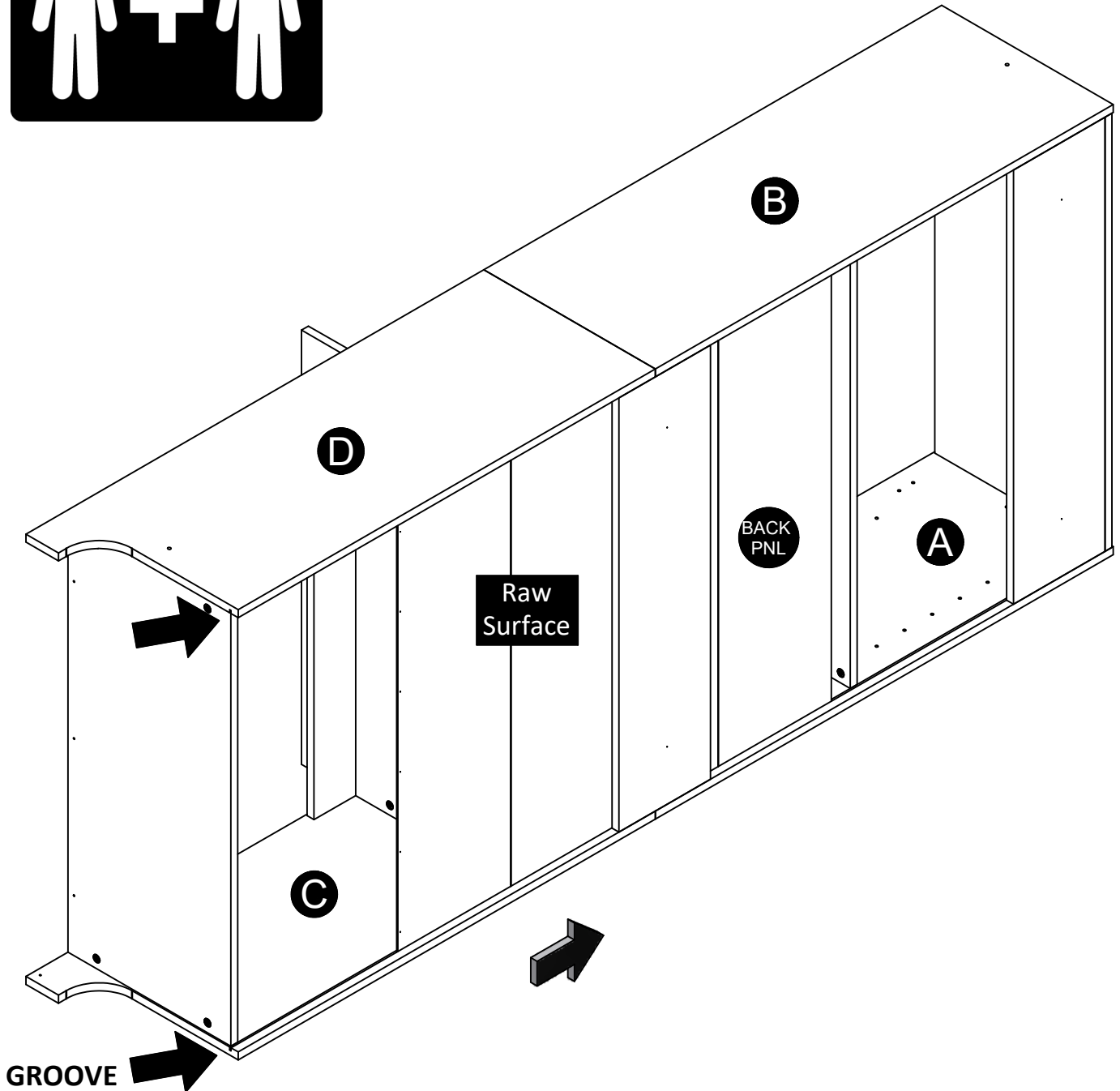

STEP 14

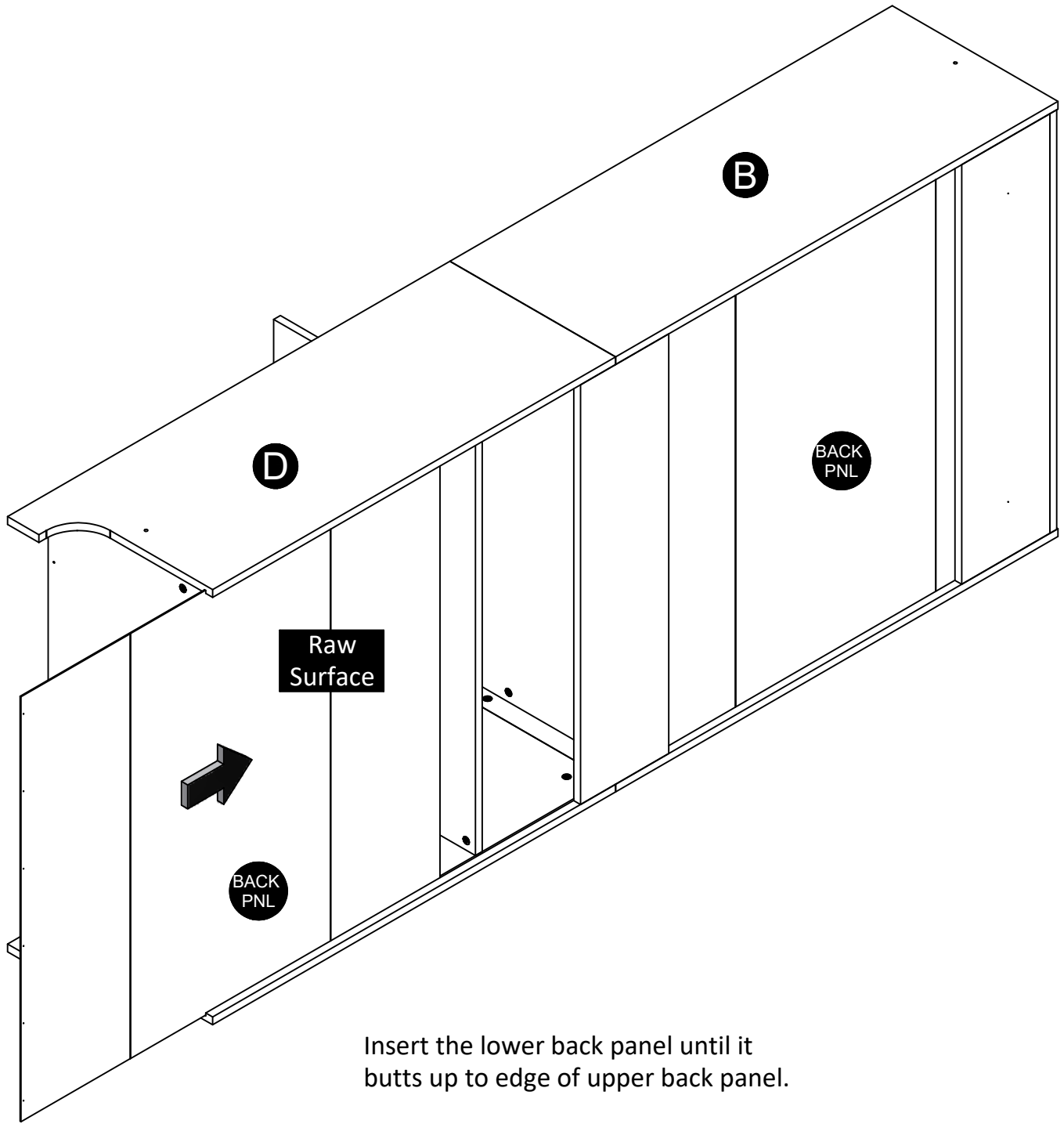

STEP 15

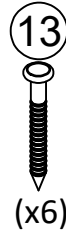
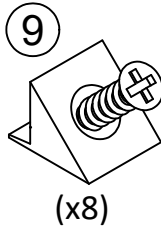
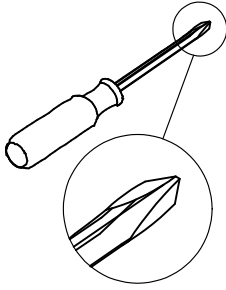
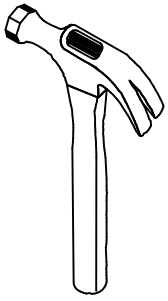

Nail the bottom Back Panel into the back edge of the Bottom (F).
Then insert eight Wedge (9) into the grooves and fasten with screws.

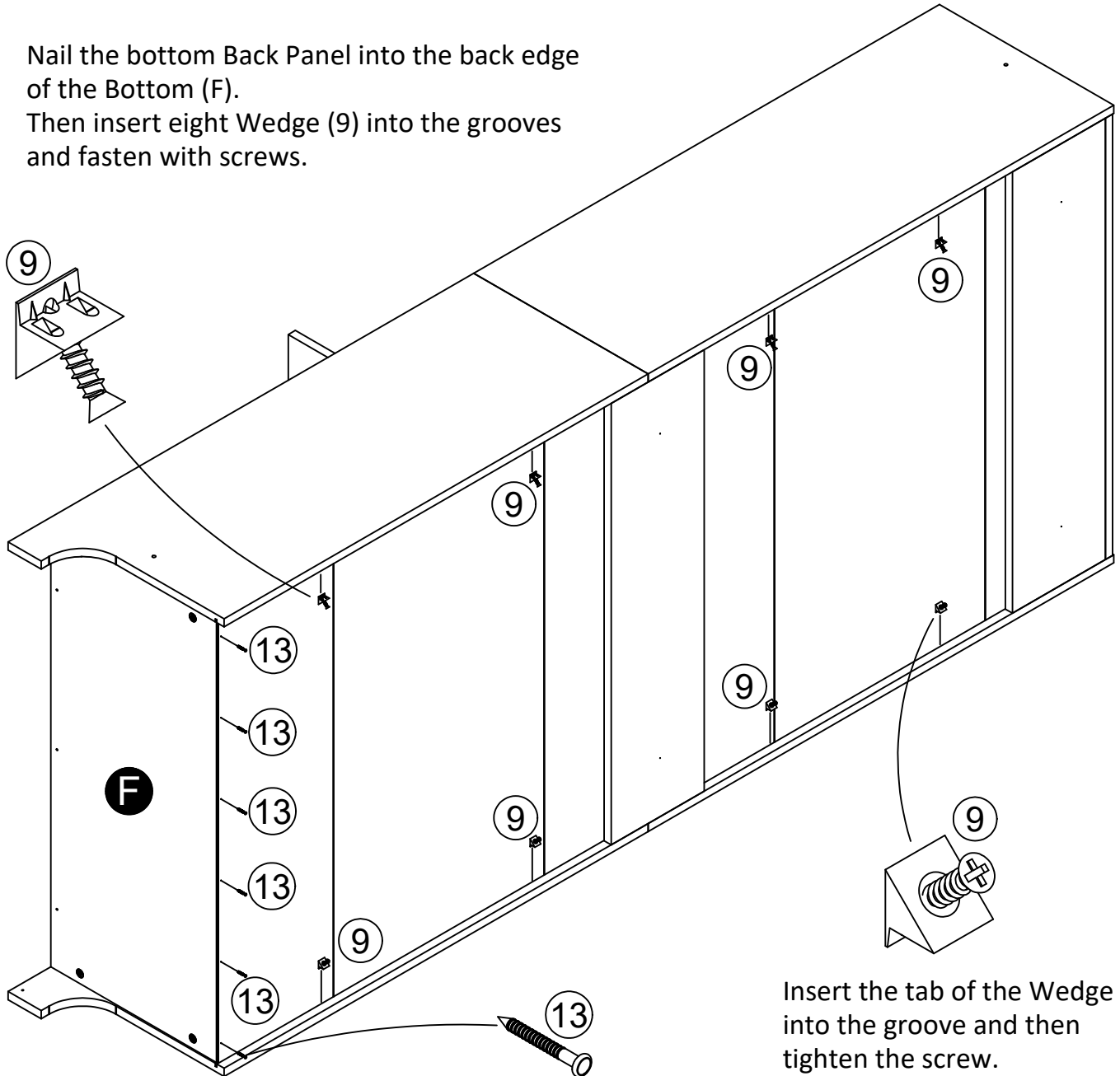

Insert the tab of the Wedge (9) into the groove and then tighten the screw.

STEP 16

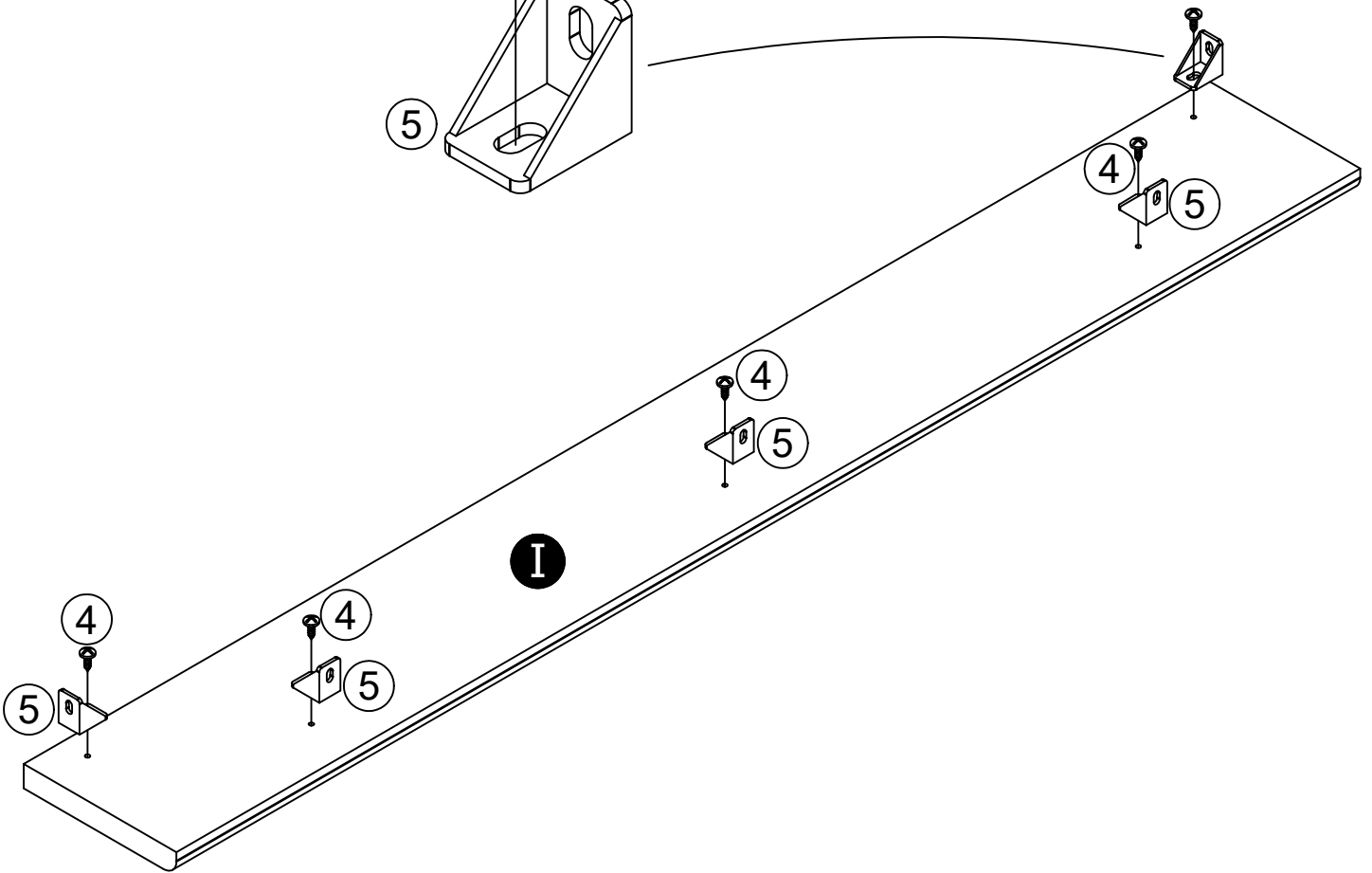
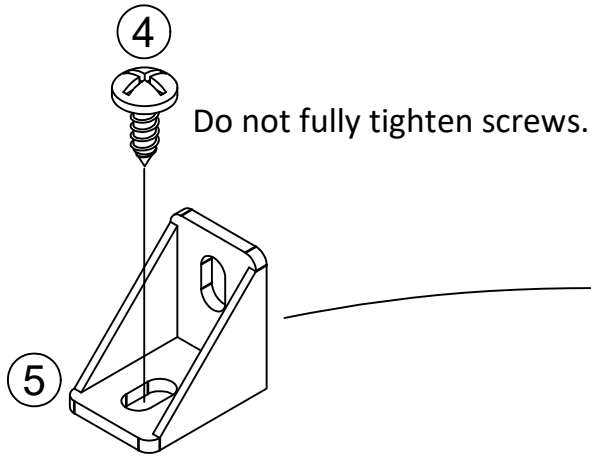
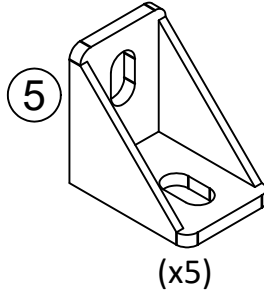
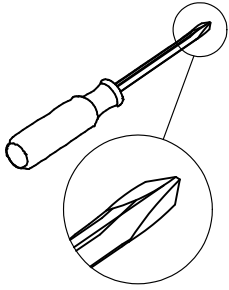

STEP 17

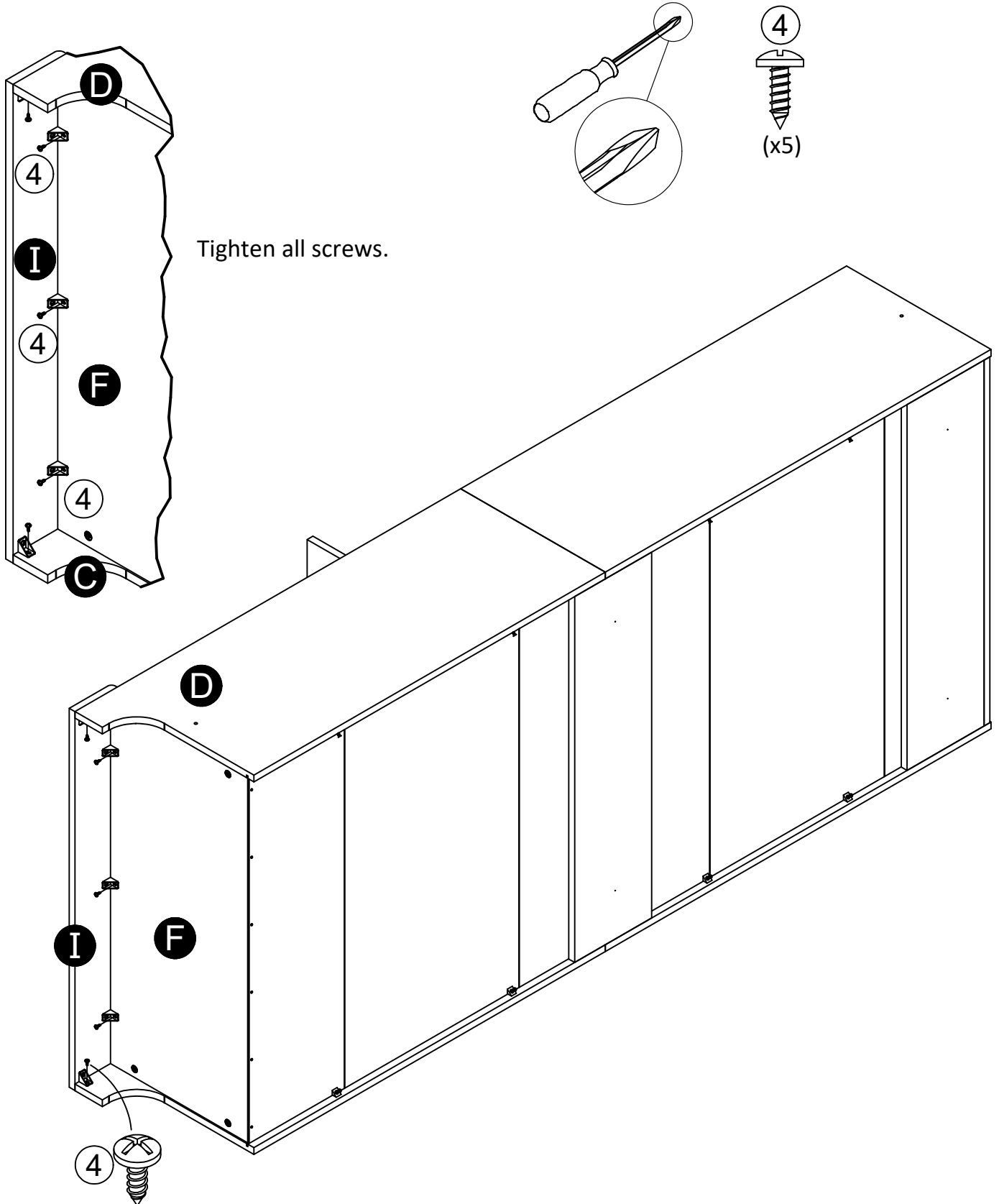

STEP 18

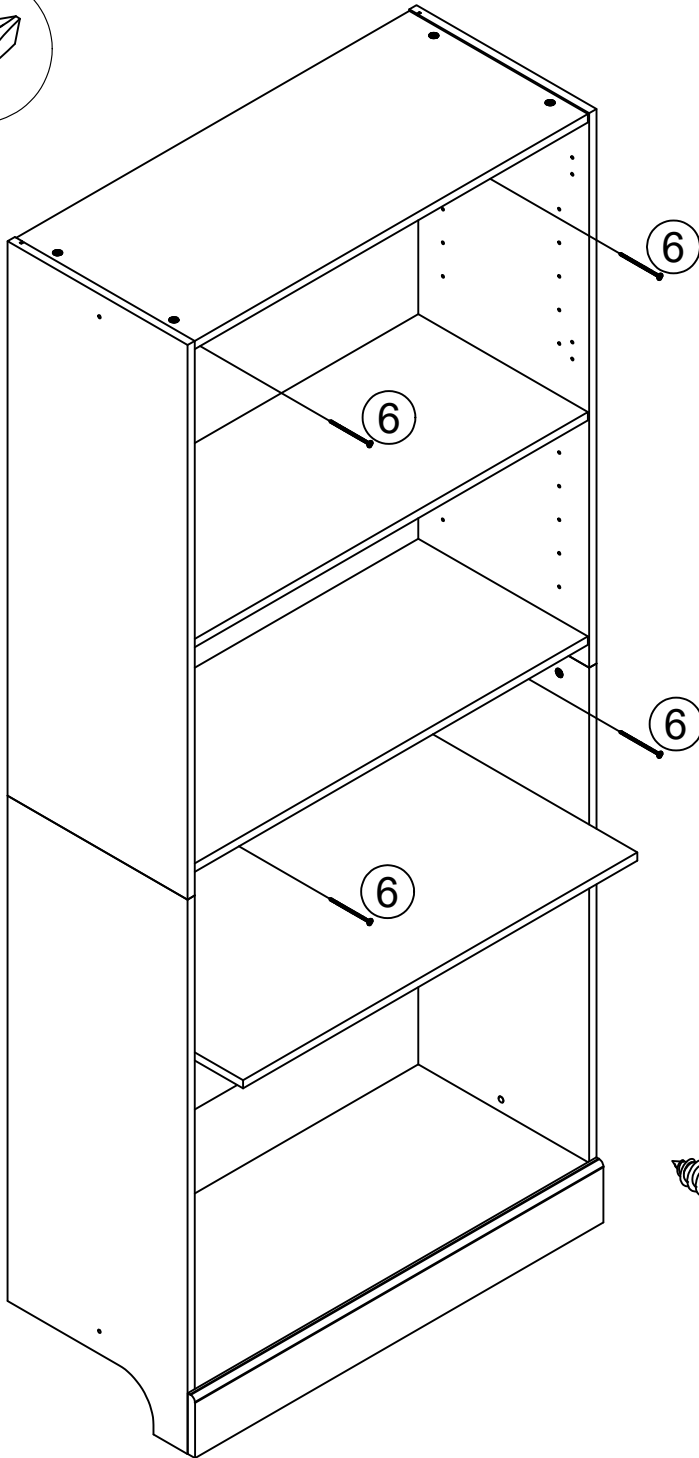
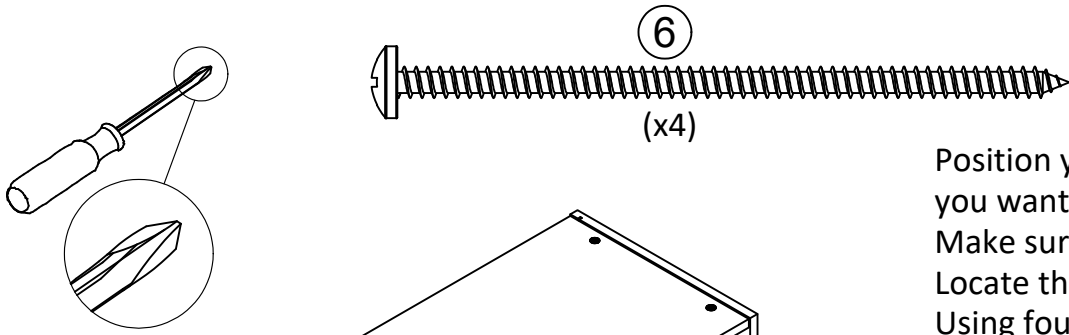

Position your Closet Unit where you want it.
Make sure the unit is level.
Locate the studs in the wall.
Using four screws (6), secure the unit to two studs. Be sure to screw thru upper and lower Support (H).

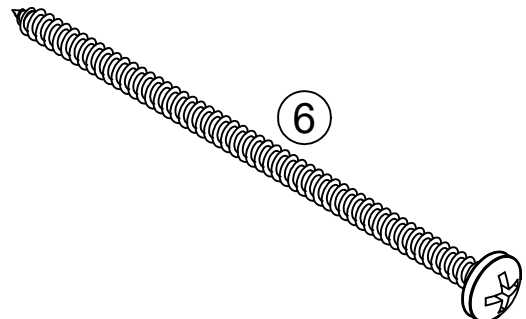
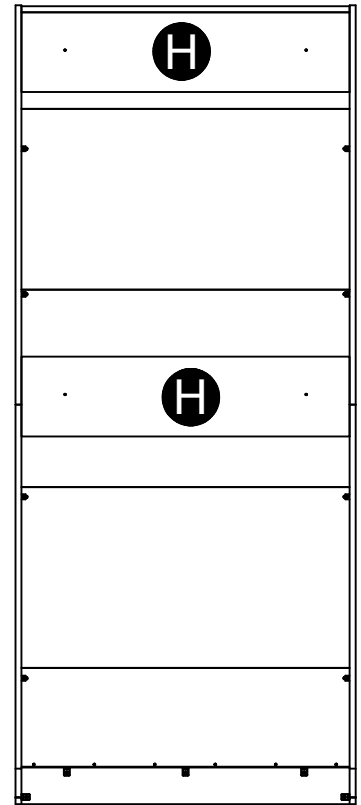

STEP 19

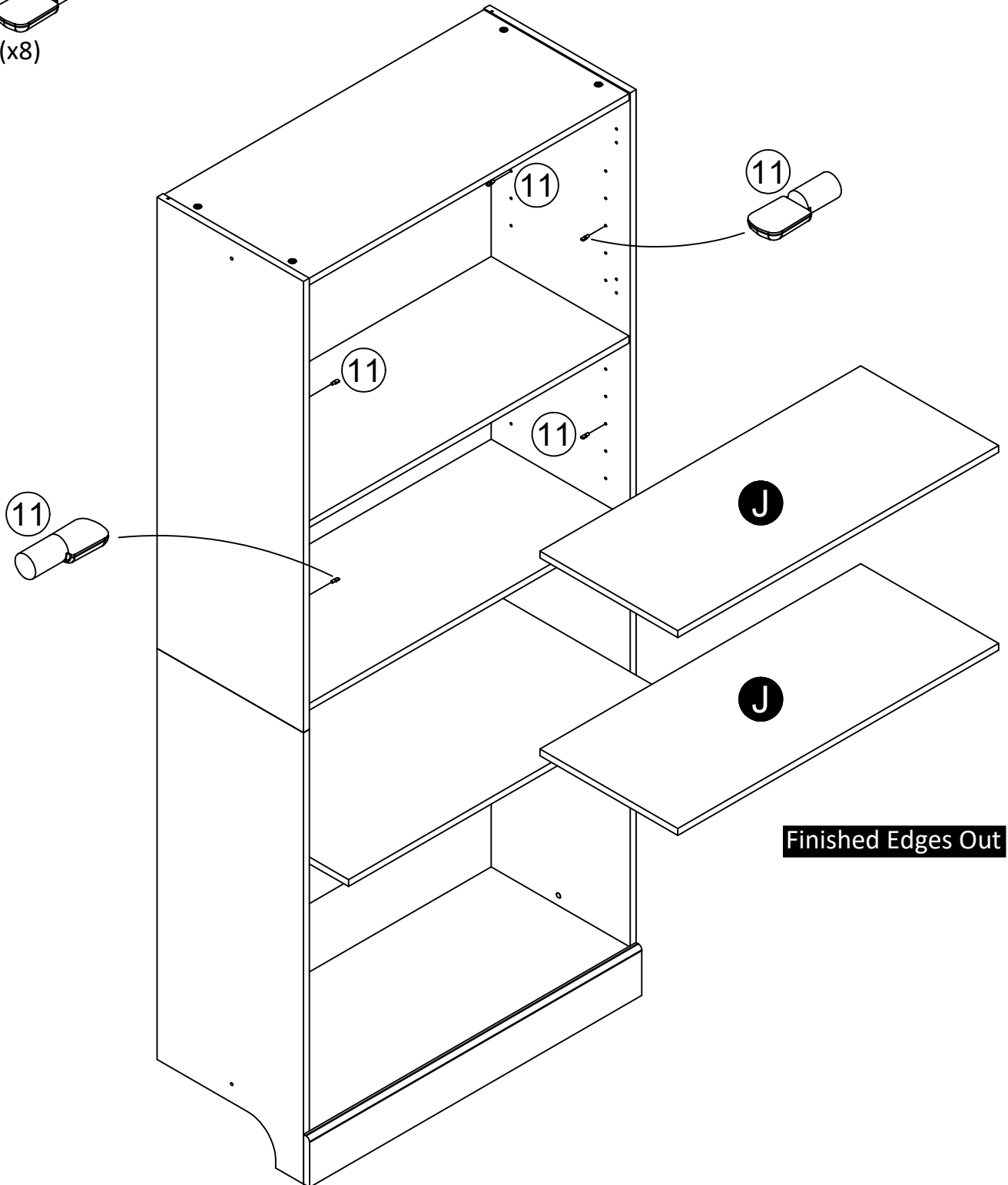
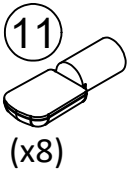

STEP 20

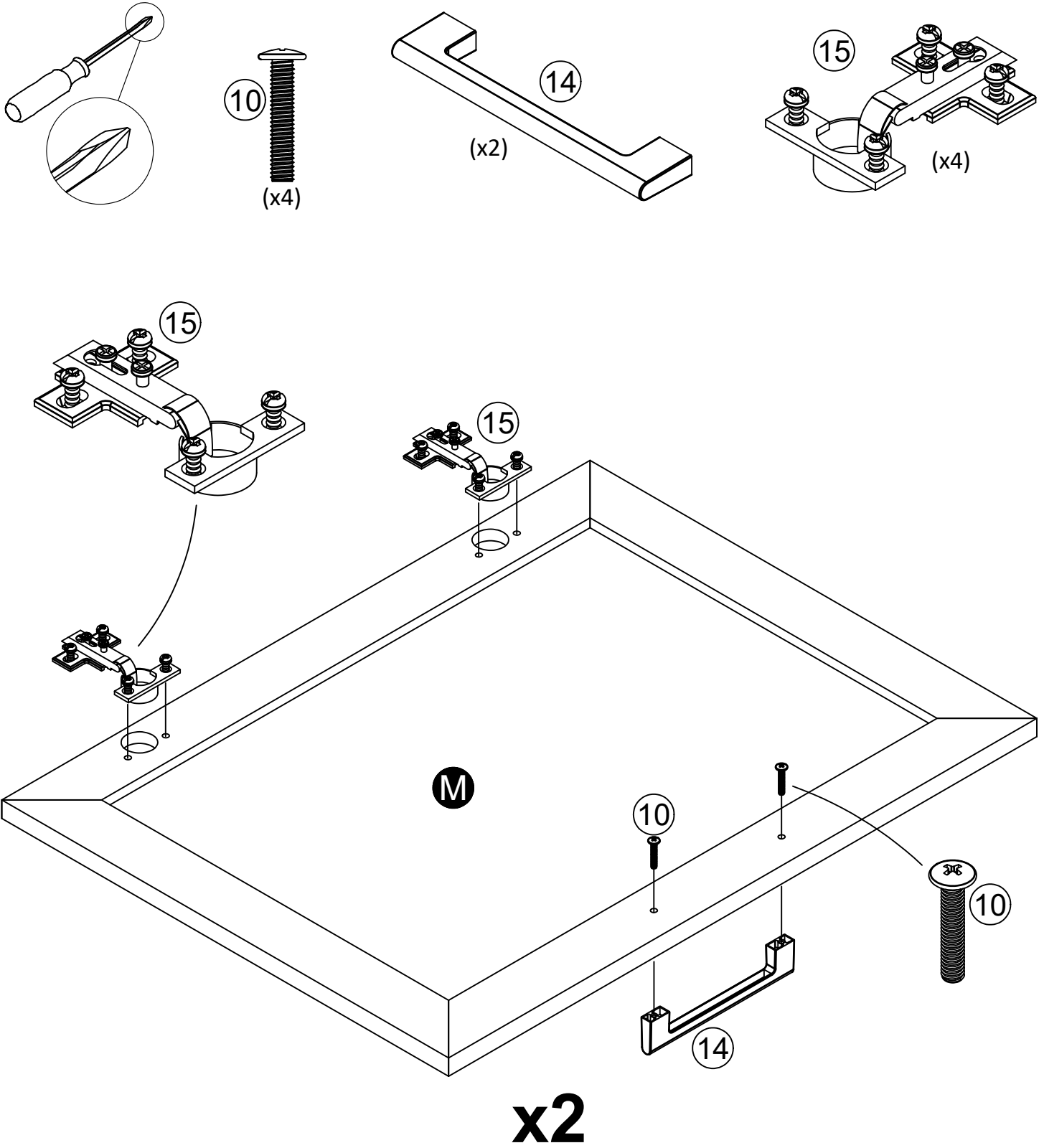

STEP 21

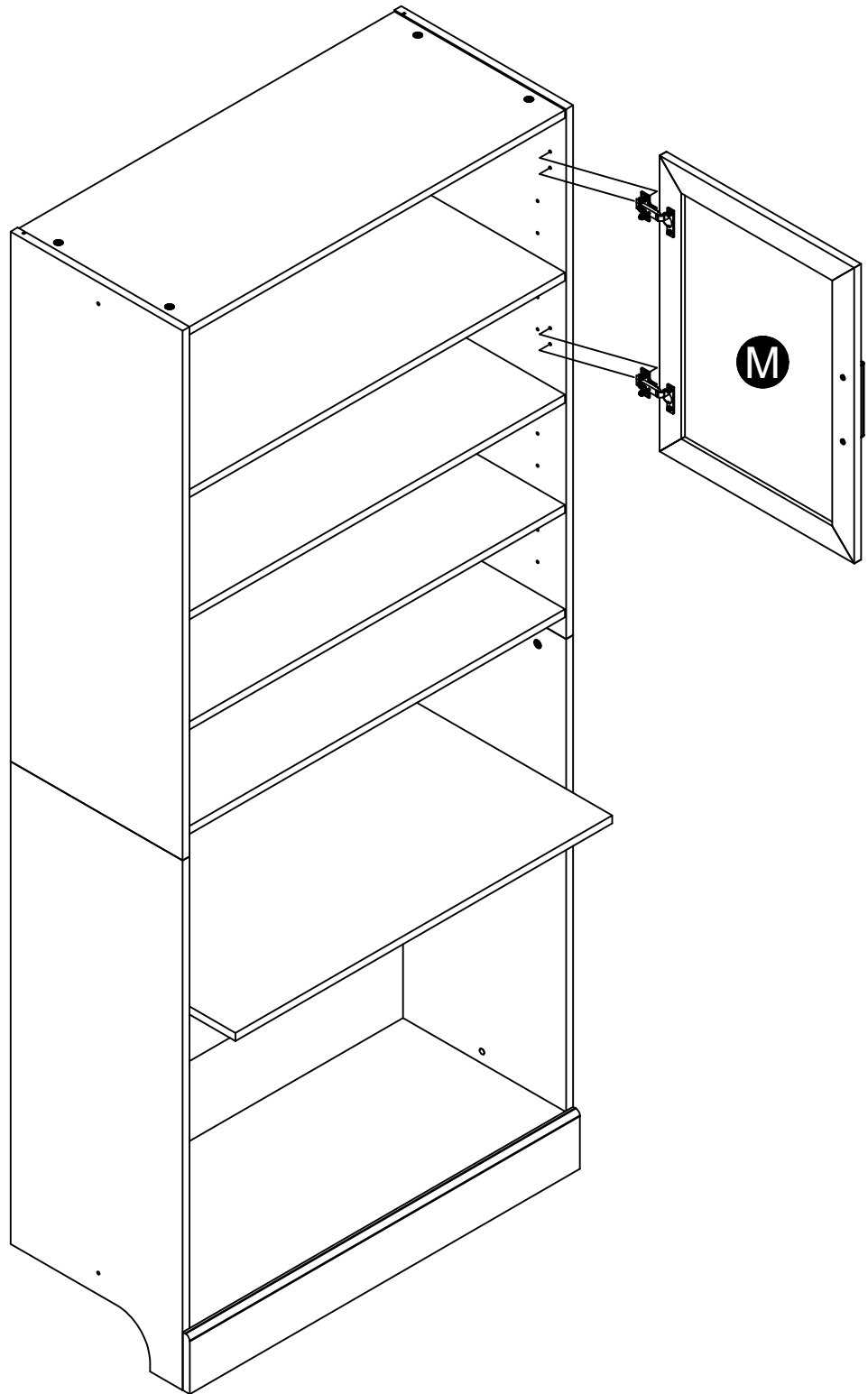
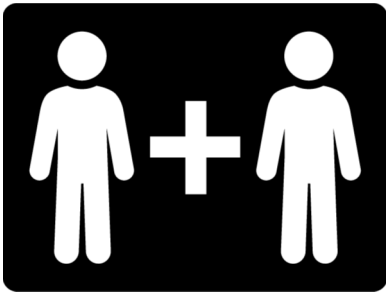
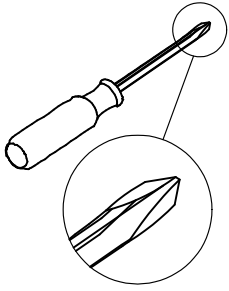

STEP 22

Door Adjustment

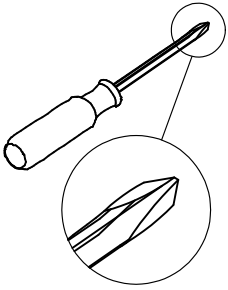

To adjust the vertical height:
Loosen the screws "A" on both hinges. They are usually in slotted holes which allows you to adjust up or down by a few mm. Then tighten back up.

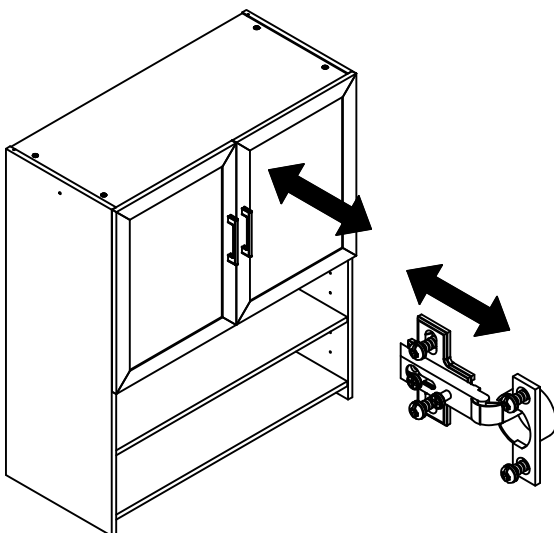
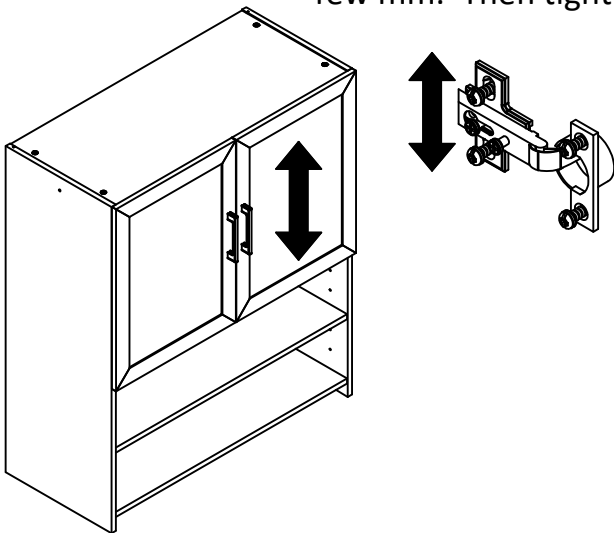
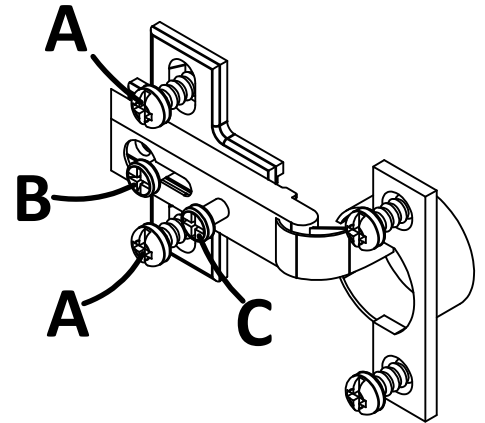

To adjust the depth:
Loosen the screw "B" and adjust door.

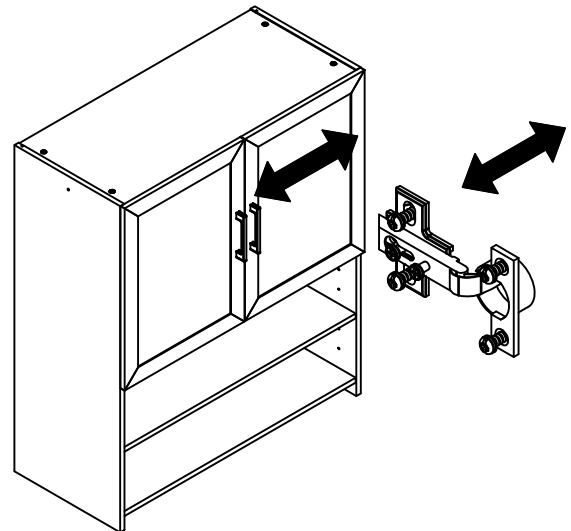

To adjust side to side:
Loosen the screw "C" on BOTH hinges and tighten "B" moves door outward. Loosen "B" and tighten "C" moves doors inward.

STEP 23

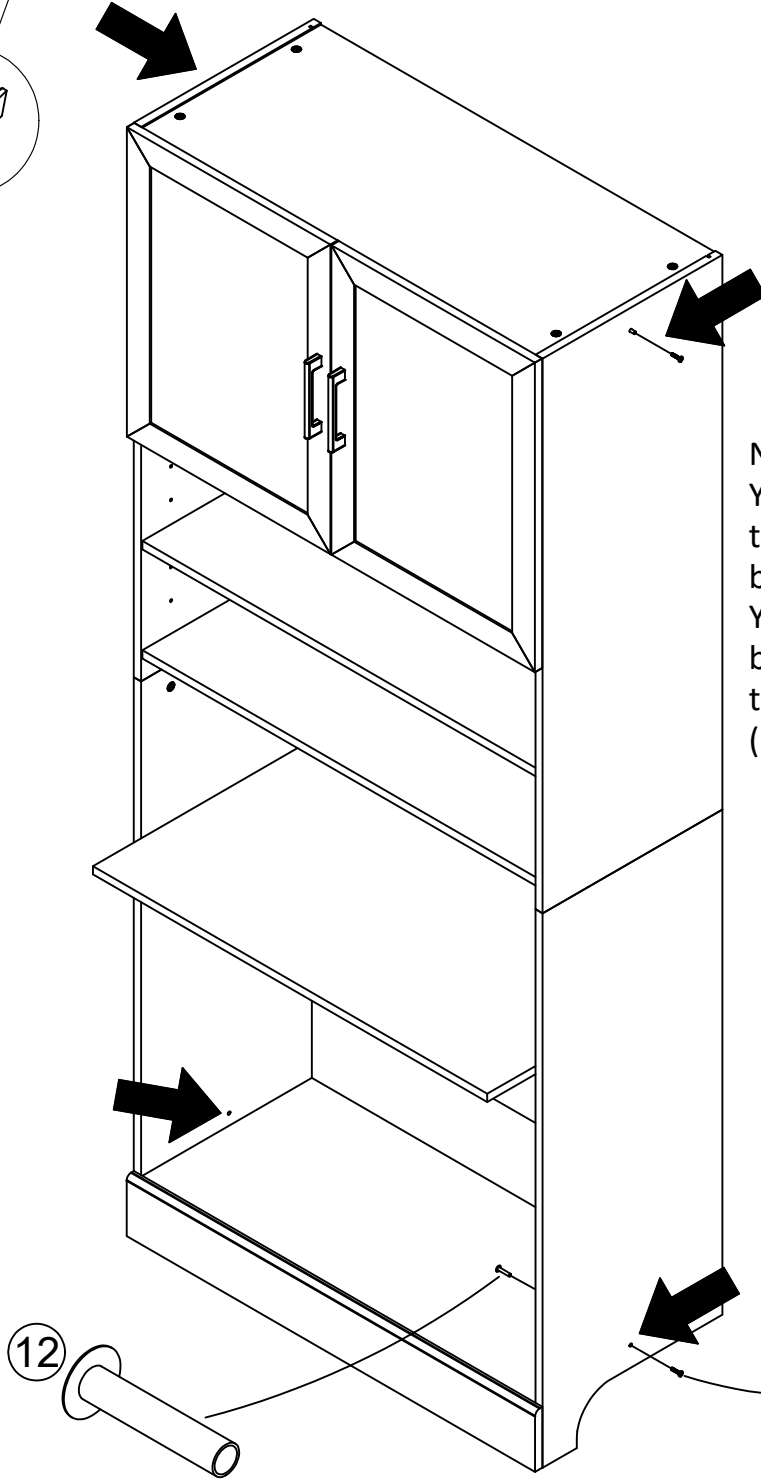
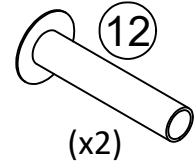
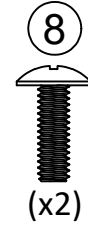
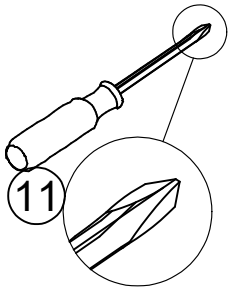

Note:
Your unit has two thru holes at the top and two thru holes at the bottom.
You can place another unit side by side and attach the two units together using two Fasteners (12) and two bolts (8).

Maximum Loads

This unit has been designed to support the maximum loads shown. Exceeding these load limits could cause sagging, instability, product collapse, and/or serious injury.

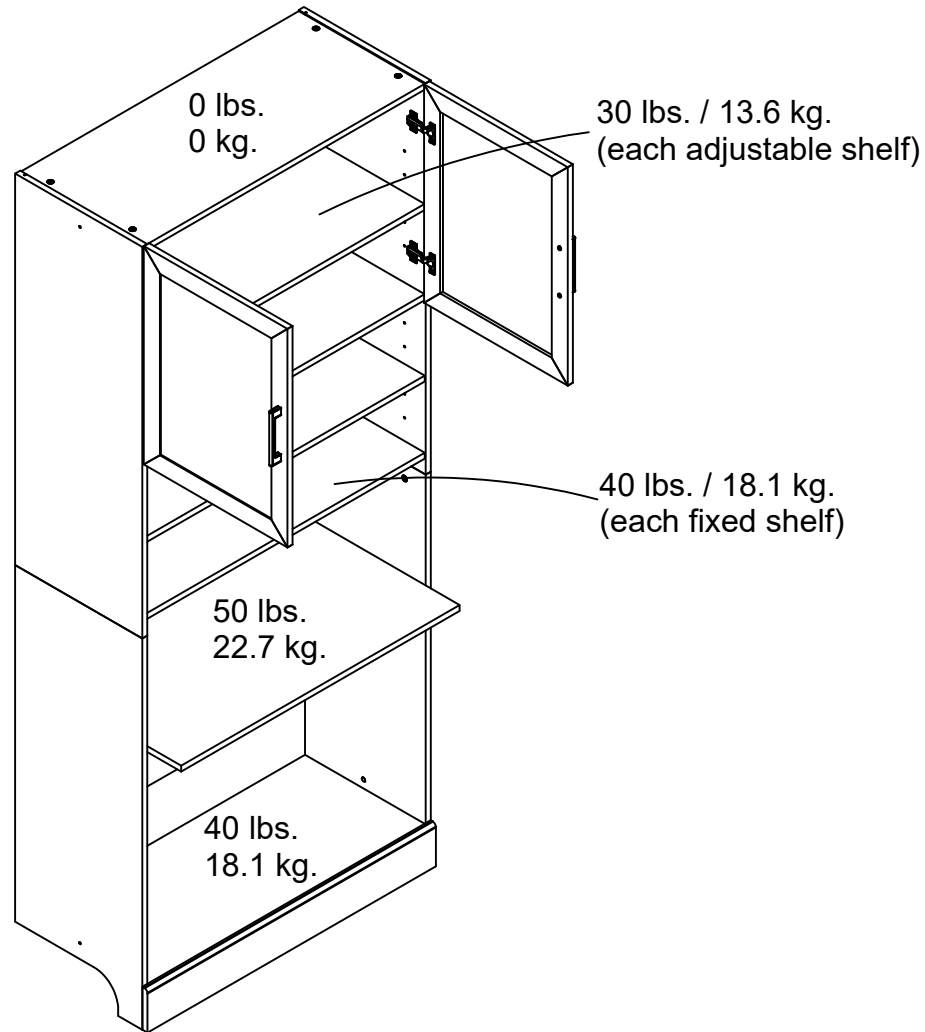

Warning: Risk of injury to persons - do not place a television on this furniture. This furniture is not approved for use with a television.

Certificate of Conformity

1. This certificate applies to the Dorel Home Furnishings, Inc. product identified by this instruction manual.
2. This certificate applies to compliance of this product with the CPSC Ban on Lead-Containing Paint (16 CFR 1303).
3. This product is distributed by: Dorel Home Furnishings, Inc.
410 East First Street South
Wright City, MO 63390
636-745-3351
4. Site of Manufacture: Tiffin OH
5. See front page of instruction manual for date of manufacture.

Register your product to receive the following:



- * New trend details - sneak peek on what's new
- * Surveys - have a voice within our community
- * Exclusive deals and discount codes
- * Quick and easy replacement part service

To register your product, visit systembuild.com

5 Star Rating



Visit your local retailer's website, rate your purchased product and leave us some feedback!

We would like to extend a big "Thank You" to all of our customers for taking the time to assemble this Systembuild product, and to give us your valuable feedback.

*Thank
You!*

Cubierta Delantera

Este libro de instrucciones contiene información **IMPORTANTE** de seguridad. Por favor lea y manténgalo para referencia en el futuro.

No Regrese este producto! Comuníquese con nuestro amigoso equipo de servicio al cliente para obtener ayuda.

Llámenos al: 1-866-452-4081 (Gratis) Lunes - Viernes 9am - 5pm CST

Visitar: www.systembuild.com

PRECAUCION

Este mueble puede volcarse y causar graves heridas y/o muerte.

Anclar el mueble a un poste de madera en la pared (si esto se requiere).

No Permita que los niños monten el mueble.

Mantenga los artículos más pesados en los cajones de abajo.

Consejos Útiles (página 2)

- Abra su artículo en el área donde usted planea utilizarlo para evitar levantar y moverlo menos
- Identificar, ordenar y contar las piezas antes de intentar ensamblar
- Las clavijas de compresión se golpean con un martillo
- Las diapositivas están marcadas con una R (derecha) y L (izquierda) para la colocación correcta
- Asegúrese de que siempre este el punto localizado en la parte superior de bloqueador de leva este volteado hacia borde exterior
- Utilizar todos los clavos para el panel de atrás y distribuirlos por igual
- El panel de atrás debe utilizarse para asegurarse de que la unidad quede fija y firme
- No use químicas fuertes ni limpiadores abrasivos en este artículo
- Nunca empuje, tire ni arrastre los muebles

Antes de Que Empieces (página 3)

- Lea cuidadosamente cada paso y siga el orden correcto
- Separar y contar todas sus piezas y hardware
- Dése suficiente espacio para el proceso de ensamble
- Tenga las siguientes herramientas: destornillador de cabeza plana, #2 cabeza Phillips
Destornillador y martillo
- Precaución: Si usa un taladro electrónico o un destornillador eléctrico para atornillar, por favor asegúrese que deje de atornillar cuando el tornillo este apretado. Fallar hacer esto puede causar barrer el tornillo.

Sistema de fijar el bloqueo de leva (página 3)

Esta sistema de fijar el bloqueo de leva sera usado en todo el proceso ensamble.

Página 13 / 14

Insertar dos Pernos de leva doble (3) y dos Clavijas de madera (7). Presionar los dos paneles para unirlos y ajustar los cuatro Pestillos con leva de fijación (1).

Página 21

¡IMPORTANTE! EL PANEL TRASERO ES UNA PARTE ESTRUCTURAL DE ESTA UNIDAD Y DEBE INSTALARSE CORRECTAMENTE.

Insertar uno de los Paneles traseros en las hendiduras y deslizarlo hasta que se inserte en la hendidura de la parte Superior (E).

Página 22

Insertar el panel trasero inferior hasta que llegue al borde del panel trasero superior.

Página 23

Clavar el Panel trasero inferior al borde posterior de la parte Inferior Bottom (F). Luego, insertar ocho Cuñas (9) en las hendiduras y ajustar con tornillos.

Insertar la pestaña de la Cuña (9) en la hendidura y luego ajustar el tornillo.

Página 24

No ajustar completamente los tornillos.

Página 26

Posicionar la Unidad Armario en el lugar deseado.

Asegurarse de que la unidad esté nivelada.

Hallar los montantes en la pared.

Utilizando cuatro tornillos (6), asegurar la unidad a dos montantes. Asegurarse de atornillar a través del Soporte (H) superior e inferior.

Página 30

AJUSTE DE PUERTA

Para ajustar la altura vertical:

Aflojar los tornillos "A" en ambas bisagras. Suelen estar en orificios ranurados que permiten ajustar algunos milímetros hacia arriba o hacia abajo. Luego, volver a ajustarlos.

Para ajustar la profundidad:

Aflojar el tornillo "B" y ajustar la puerta.

Para ajustar lado a lado:

Aflojar el tornillo "C" en AMBAS bisagras y ajustar el "B" mueve la puerta hacia afuera. Aflojar el "B" y ajustar el "C" mueve la puerta hacia adentro.

Página 31

Importante:

La unidad tiene dos perforaciones en la parte superior y dos perforaciones en la parte inferior. Puede colocar otra unidad al lado y unir las utilizando dos sujetadores (12) y dos tornillos (8).

Página 32

CARGA MAXIMA

Esta unidad fue diseñada para soportar las cargas máximas que se muestran. Exceder esos límites de carga podría causar inclinación, inestabilidad, colapso del producto y/o lesiones graves.

Advertencia: Riesgo de lesión para personas - no colocar un televisor sobre este mueble. Este mueble no está aprobado para ser utilizado con un televisor.

Página 33

Registre su producto para recibir lo siguiente:

- * Detalles de nuevas tendencias - Vistazo a lo nuevo
- * Encuestas - alee su voz entre su comunidad
- * Códigos de ofertas y descuentos exclusivos
- * Fácil y rápido servicio de partes de remplace

Para registrar su producto, visite systembuild.com

Clasificación de 5 estrellas

Visite el sitio web de su tienda local, califique su comprado y denos sus comentarios!

Nos gustaría enviar un gran "Agradecimiento" a todos nuestros clientes por tomarse el tiempo de ensamblar este producto de Systembuild, y por darnos sus valiosos comentarios.

Gracias

Couverture Avant

CE LIVRET D'INSTRUCTION CONTIENT DES INFORMATIONS **IMPORTANTES** SUR LA SÉCURITÉ. VEUILLEZ LIRE ET GARDER POUR UNE RÉFÉRENCE FUTURE

Ne retournez pas ce produit! Contactez notre équipe de service à la clientèle amicale d'abord pour obtenir de l'aide.

Appelez-nous: 1-866-452-4081 (sans frais) du Lundi au Vendredi de 9h à 17h Heure Centrale

Visitez: www.systembuild.com

ATTENTION

Le meuble peut basculer et causer des blessures graves ou la mort.

Ancrer le meuble à une planche murale dans le mur (si indiqué).

Ne laissez pas les enfants grimper sur le meuble.

Placez les articles lourds sur les étagères ou dans les tiroirs inférieurs.

Astuces Utiles (page 2)

-Ouvrez votre article dans la zone que vous prévoyez de le garder pour moins de levage lourd

-Identifier, trier et compter les pièces avant d'essayer d'assembler

-Les goujons de compression sont taraudés avec un Marteau

-Les glissières sont marquées d'un R (droit) et d'un L (gauche) pour un bon placement

-Assurez-vous toujours de faire face la pointe situé sur le haut de la Serrure de Came vers le bord extérieur

-Utiliser tous les clous fournis pour le panneau arrière et les répartir également

-Le panneau arrière doit être utilisé pour vous assurer que votre appareil est robuste

-N'utilisez pas de produits chimiques agressifs ou de nettoyeurs abrasifs sur cet appareil

-Ne jamais pousser, tirer, ou faire glisser votre meuble

Avant de Commencer (page 3)

-Lisez attentivement chaque étape et suivez le bon ordre

-Séparez et comptez toutes vos pièces et matériaux

-Donnez-vous suffisamment de place pour l'assemblage

-Avoir les outils suivants: tournevis à tête plate, #2 tournevis Phillips, et Marteau

-Attention: Si vous utilisez une perceuse électrique ou un tournevis électrique pour visser, veillez à ralentir et arrêter lorsque la vis est bien serrée. Le non-respect de cette consigne peut endommager la vis.

Système de Fixation de Came (page 3)

Ce Système de Fixation de Came sera utilisé tout au long de l'assemblage

Page 13/14

Insérez deux boulons à double came (3) et deux chevilles à bois (7). Pressez les deux panneaux ensemble et serrez les quatre verrous à came (1).

Page 21

IMPORTANT! LE PANNEAU ARRIÈRE EST UNE PARTIE ESSENTIELLE DE CET APPAREIL ET DOIT ÊTRE INSTALLÉ CORRECTEMENT.

Insérez l'un des panneaux arrière dans les rainures et faites-le glisser jusqu'à ce qu'il s'insère dans la rainure du dessus (E).

Page 22

Insérez l'un des panneaux arrière dans les rainures et faites-le glisser jusqu'à ce qu'il s'insère dans la rainure du dessus (E).

Page 23

Clouez le panneau arrière inférieur dans le bord arrière du fond (F).
Insérez ensuite huit cales (9) dans les rainures et fixez-les avec des vis.

Insérez la languette de la cale (9) dans la rainure, puis serrez la vis.

Page 24

Ne serrez pas complètement les vis.

Page 26

Placez votre unité de placard là où vous le souhaitez.

Assurez-vous que l'unité est de niveau.

Localisez les montants du mur.

À l'aide de quatre vis (6), fixez l'unité à deux montants. Veillez à visser à travers les supports supérieur et inférieur (H).

Page 30

AJUSTEMENT DE LA PORTE

Pour régler la hauteur verticale :

Desserrez les vis « A » des deux charnières. Elles sont généralement dans des trous oblongs qui vous permettent de les régler de quelques millimètres vers le haut ou vers le bas. Puis resserrez-les.

Pour ajuster la profondeur :

Desserrez la vis « B » et réglez la porte.

Pour ajuster d'un côté à l'autre :

Desserrez la vis « C » sur les DEUX charnières et serrez « B » pour déplacer la porte vers l'extérieur.

Desserrez la vis « B » et serrez la vis « C » pour déplacer la porte vers l'intérieur.

Page 31

Remarque :

Votre unité a deux trous traversants en haut et deux trous traversants en bas.

Vous pouvez placer une autre unité côte à côte et fixer les deux unités ensemble à l'aide de deux attaches (12) et de deux boulons (8).

Page 32

CHARGES MAXIMALES

Cet appareil a été conçu pour supporter les charges maximales indiquées. Le dépassement de ces limites de charge peut entraîner un affaissement, une instabilité, un effondrement du produit et/ou des blessures graves.

Avertissement : Risque de blessure pour les personnes -- ne pas placer un téléviseur sur ce meuble. Ce meuble n'est pas homologué pour être utilisé avec un téléviseur.

Page 33

Enregistrez votre produit pour recevoir les éléments suivantes:

- * Détails sur les nouvelles tendances - un aperçu sur les nouveautés
- * Sondages - avoir une voix au sein de notre communauté
- * Offres exclusives et codes promo
- * Service de pièces de rechange rapide et facile

Pour enregistrer votre produit, visitez systembuild.com

5 Étoiles

Visitez le site Web de votre détaillant local, évaluez votre produit acheté et laissez-nous quelques commentaires !

Nous tenons à offrir un grand "Merci" à tous nos clients pour avoir pris le temps d'assembler ce produit "Systembuild", et de nous donner vos commentaires précieux.

Merci